

FAN COIL WITH GERMICIDAL LAMP

FHX

UV

UVP

UVPO



IFHXTY
0809
4267320_00

INDEX

DECLARATION OF CONFORMITY	4
Carriage • Safety symbol	5
Important information	6
Description • Versions	7
Main components • Component description	8
Selection	9
System configuration	10
Technical data	11
Operating limits	15
Delivery cooling capacity	16
Heating power input (3R)	22
Heating power input (4R)	23
Hanging version available static pressure	24
Battery pressure drop	25
Correction factors in functioning with glycoled water	26
Sound power and sound pressure	27
Sound power level for ducted wall/ceiling-mounting models	29
Accessories	30
Unit installation	39
Electrical connections	40
Replacing the lamps	40
Dip-Switch	41
Rotating the coil	42
Technical areas	43
Dimensions	43
Wiring diagram	45

REMARKS

Store the manuals in a dry location to avoid deterioration, as they must be kept for at least 10 years for any future reference. **All the information in this manual must be carefully read and understood. Pay particular attention to the operating standards with “DANGER” or “WARNING” signals as failure to comply with them can cause damage to the machine and/or persons or objects.**

If any malfunctions are not included in this manual, contact the local After-sales Service immediately.

The apparatus must be installed in such a way that maintenance and/or repair operations are possible.

The apparatus's warranty does not in any case cover costs due

to automatic ladders, scaffolding or other lifting systems necessary for carrying out repairs under guarantee.

Normal wear of components and filter is not covered by the warranty.

AERMEC S.p.A. declines all responsibility for any damage whatsoever caused by improper use of the machine, and a partial or superficial acquaintance with the information contained in this manual.

The number of pages in this manual is: 48.

TRASPORTO • CARRIAGE • TRANSPORT • TRANSPORT • TRANSPORTE

NON bagnare • Do NOT wet
CRAINT l'humidité • Vor Nässe schützen
NO mojar



NON calpestare • Do NOT trample
NE PAS marcher sur cet emballage • Nicht betreten
NO pisar

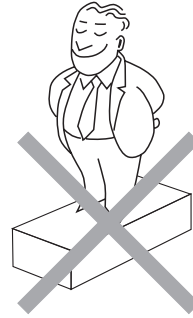

Sovrapponibilità: controllare sull'imballo la posizione della freccia per conoscere il numero di macchine impilabili.
Stacking: control the packing for the arrow position to know the number of machines that can be stacked.
Empilement: vérifier sur l'emballage la position de la flèche pour connaître le nombre d'appareils pouvant être empilés.
Stapelung: Anhand der Position des Pfeiles an der Verpackung kontrollieren, wieviele Geräte stapelbar sind.
Apilamiento: observe en el embalaje la posición de la flecha para saber cuántos equipos pueden apilarse.

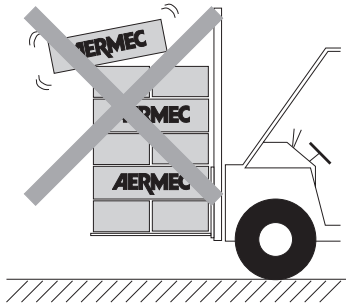
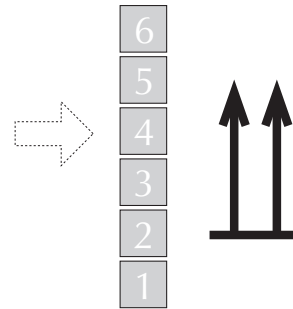

NON lasciare gli imballi sciolti durante il trasporto.
Do NOT leave loose packages during transport.
ATTACHER les emballages pendant le transport.
Die Verpackungen nicht ungesichert transportieren.
NO lleve las cajas sueltas durante el transporte.

NON trasportare la macchina da soli se il suo peso supera i 35 Kg.
DO NOT handle the machine alone if its weight is over 35 Kg.
NE PAS transporter tout seul l'appareil si son poids dépasse 35 Kg.
Das Gerät NICHT alleine tragen, wenn sein Gewicht 35 Kg überschreitet.
NO maneje los equipos en solitario si pesan más de 35 kg.

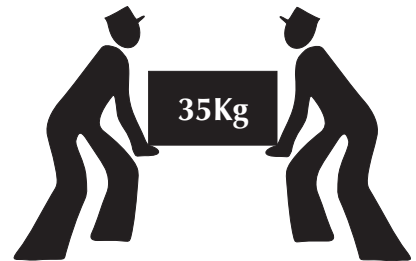

SIMBOLI DI SICUREZZA • SAFETY SYMBOL • SIMBOLES DE SECURITE
SICHERHEITSSYMBOL • SÍMBOLOS DE SEGURIDAD



Pericolo:
Tensione
Danger:
Power supply
Danger:
Tension
Gefahr !
Spannung
Peligro:
Tensión



Pericolo:
Organi in movimento
Danger:
Movings parts
Danger:
Organes en mouvement
Gefahr !
Rotierende Teile
Peligro:
Elementos en movimiento



Pericolo!!!
Danger!!!
Danger!!!
Gefahr!!!
Peligro!!!

IMPORTANT INFORMATION AND MAINTENANCE

WARNING: the electrical wirings, the installation of the fan coils and their accessories, maintenance and the yearly replacement of the germicidal lamps must be performed only by a technician who has the necessary technical and professional qualifications to install, modify, extend and service the systems and who is capable of assessing these systems for the purposes of safety and functionality.

WARNING: before carrying out any work, wear the proper personal protective equipment.

WARNING: the fan coil is connected to the power supply and a water circuit. Any operation by persons who do not possess the required technical skills can lead to personal injury to the operator or damage to the unit and surrounding objects.

WARNING: The appliance must be fitted according to the national regulation on process plant engineering.

WARNING: Check that the power supply is disconnected before carrying out any procedures on the unit.

WARNING: Install a device, main switch or plug which makes it possible to completely cut off the power supply from the unit.

DANGER! The UVC radiation emitted by the germicidal lamp is dangerous and may cause conjunctivitis, burns and erythema.

It is absolutely prohibited to operate the device with the germicidal lamp when it has been removed from the fan coil.

It is absolutely prohibited to operate the device with the germicidal lamp if the fan coil has not been adequately installed.

WARNING! DANGER! Any use of the unit not expressly indicated by Aermec is strictly prohibited.

MALFUNCTIONS

In the event of a malfunction, cut off power supply to the unit, then restore the power and start the unit again. If the problem occurs again, contact your After Sales Service department immediately.

ONLY POWER THE FAN COIL AT 230 V_{AC} 50 HZ

Any other type of power supply could permanently damage the fan coil.

DO NOT USE THE FAN COIL IMPROPERLY

Do not use the fan coil in animal husbandry applications (e.g. incubation).

AIRING THE ROOM

Periodically air the room in which the fan coil has been installed. This is particularly important if the room is occupied by many people, or if gas appliances or sources of odours are present.

DURING OPERATION

Always leave the filter fitted on the fan coil during operation (otherwise dust in the air could soil the coil surface area).

CORRECT TEMPERATURE ADJUSTMENT

The room temperature should be regulated in order to provide maximum comfort to the people in the room, especially if they are elderly, children or ill; avoiding temperature differences of more than 7°C between outside and inside the room in summer.

In summer, a temperature that is too low causes higher electrical consumption.

CORRECT AIR JET AIMING ADJUSTMENT

The air coming out of the fan coil must not impact directly on people; in fact, even if temperature is higher than the room temperature, it could cause a cold sensation resulting in discomfort.

DO NOT USE EXCESSIVELY HOT WATER

Clean the fan coil with a soft cloth or sponge soaked in water not over 40 °C. Do not use chemical products or solvents to clean any part of the fan coil. Do not spray water on the outer or inner surfaces of the fan coil (it might cause short circuits).

CLEAN THE FILTER FREQUENTLY

Before performing any maintenance procedures requiring access to the internal parts of the fan coil, cut off the power supply in order to avoid being exposed to the light emitted by the lamp.

Cleaning the filter frequently guarantees enhanced operating efficiency.

Check whether the filter is very dirty: if it is, clean it more often.

Clean frequently; remove the accumulated dust with a vacuum cleaner.

Once the filter is clean, refit it to the fan coil following the removal instructions but in reverse order.

SUPPLEMENTARY CLEANING

Before performing any maintenance procedures requiring access to the internal parts of the fan coil, cut off the power supply in order to avoid being exposed to the light emitted by the lamp.

The fact that the blades of inspectable shrouds can be removed (operation done only by adequately skilled technicians) ensures a thorough cleaning of the internal components, which is particularly important when installing the unit in crowded areas or venues requiring high hygiene standards.

WHAT IS NORMAL

In the cooling function, water vapour may be present in the air delivery of the fan coil.

In the heating function, a slight hiss might be heard close to the fan coil. Sometimes the fan coil might give off unpleasant smells due to the accumulation of substances present in the air of the environment (clean the filter more often especially if the room is not ventilated regularly).

During the operation, there could be noises and creaks inside the device, due to the various thermal expansions of the elements (plastic and metallic), but this does not indicate any malfunction and does not damage the unit unless the maximum input water temperature is exceeded.

REPLACING THE LAMPS

This procedure may only be performed by people with the necessary specific technical skills.

Before performing any maintenance procedures requiring access to the internal parts of the fan coil, cut off the power supply in order to avoid being exposed to the light emitted by the lamp.

Never let yourself come into direct contact with the light produced by the lamp, as the UVC radiation may cause serious eye and skin irritation.

Lamps should be replaced every year in order to ensure that the germicidal action remains constant.

PACKAGING

The fan coils are shipped in standard packaging which consists of expanded polystyrene foam and cardboard shells.

USE

Consult the control panel manual for operating instructions.

FHX - FAN COIL WITH GERMICIDAL LAMP

Congratulations on your purchase of this Aermec FHX fan coil.

Made with materials of superior quality in strict compliance with safety regulations, "FHX" is easy to use and will have a long life.

The **FHX** fan coil concentrates high technological and functional characteristics that make it the ideal climate control unit for all types of rooms. The supply of climate-controlled air is immediate and distributed throughout the room. **FHX** generates heat if included in a heating system with boiler or heat pump, but may also be used in summer as an air conditioner if the heating system has a water chiller.

The FHX fan coil is fitted with an exclusive device featuring a mercury-vapour germicidal lamp for air sterilisation, offering anti-microbiological action which is 99.999% effective in combating all Gram - and Gram + microorganisms. The germicidal lamp, positioned in the air delivery flow, cleans the coil more thoroughly and prevents the formation of mould on the surface of the fins, thereby ensuring the unit operates at its maximum efficiency level in the long term, while reducing the need for coil cleaning procedures.

The fact that the tray and the fan shrouds can be inspected means you can carefully clean the internal parts as well.

These characteristics make the FHX unit indispensable in venues requiring high hygiene standards, such as:

- hospitals
- dentists' surgeries
- doctors' and vets' consulting rooms
- clinical analysis laboratories
- pharmaceutical companies
- waiting rooms
- beauty salons
- homes
- offices
- public premises

The new centrifugal fan unit is so quiet that at a normal operating speed you cannot hear when the **FHX** cuts in.

All models in the **FHX** range are supplied without a control panel.

The PXAI and PXAE combinable control panels are supplied as accessories; they activate the germicidal lamp operation as well as the ventilation function, and are fitted with an electronic thermostat which controls fan coil operation in order to maintain the set temperature in the room. They also make electronic temperature adjustment and manual/automatic fan speed adjustment possible, while the heating or cooling operating mode is selected automatically (change of season) and depends on the temperature of the water circulating inside the system.

The PXAI control panel may be fitted underneath the flap to the right of the **FHX_UV** fan coil.

The PXAE control panel to be wall-mounted may be used combined with all versions of the **FHX** range.

The fan coils in the **FHX** range are designed to satisfy all system requirements, thanks to the wide range of accessories available.

Full compliance with accident prevention regulations.

English

VERSIONS

Available in 3 versions and 6 sizes with a 3-row coil and, only for ducted versions, in 6 sizes with a 4-row coil:

FHX 22 - 24
FHX 32 - 34
FHX 42 - 44
FHX 50 - 54
FHX 62 - 64
FHX 82 - 84

FHX_UV: with a 3-row coil, a 3-speed motor, universal cabinet for vertical and horizontal installation and anti-corrosive polyester powder coated finish, RAL 9002. The air delivery and suction louvers are made of plastic material, RAL 7044.

The control panel may be fitted on board the unit (PXAI accessory) or externally (PXAE accessory).

FHX_UVP: with 3- or 4-row coils, version without casing, with a 3-speed motor, for horizontal and vertical wall installation, requires external control panel (PXAE accessory).

FHX_UVPO: with 3- or 4-row coils, version without casing, with a boosted motor set to operate at 7 speeds (3 of which may be selected), for horizontal and vertical ceiling installation, requires external control panel (PXAE accessory).

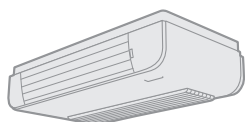

FHX 22 ÷ 50 UV

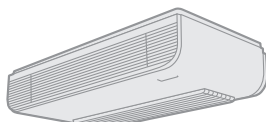

FHX 62 - 82 UV

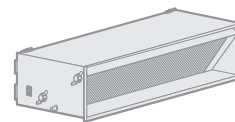

FHX UVP - UVPO

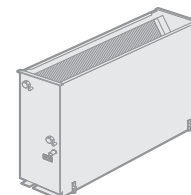
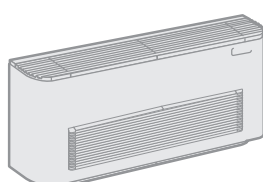
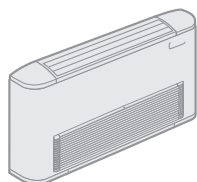

MAIN COMPONENTS

- | | |
|--------------------------------|---------------------------------------|
| 1 Heat exchange coil | 6 Load-bearing structure |
| 2 Air filter | 7 Condensate drain |
| 3 Protective cabinet (RAL9002) | 8 Plumbing connections |
| 4 Fan motor | 9 Head with orientable fins (RAL7044) |
| 5 Fan | 10 Germicidal lamp |

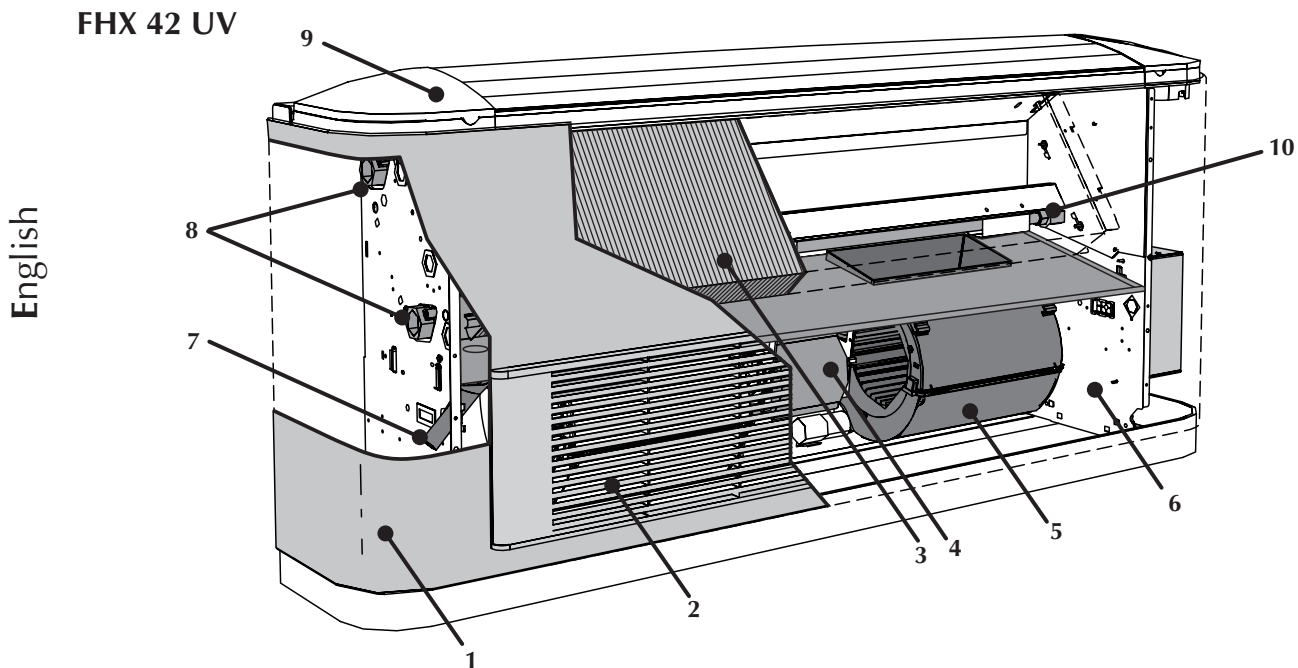

DESCRIPTION OF COMPONENTS

HEAT EXCHANGE COIL

Coil with copper pipe and aluminium fins held in place by means of the mechanical expansion of the pipes. The manifolds are fitted with female connections and air vents in the upper part of the coil.

FILTRATION SECTION

Easily removable and made from regenerable materials. May be cleaned by washing. P and PO versions are equipped with G2 class filter.

CABINET

Casing in RAL9002

Air delivery and suction louvers in RAL7044

Made from specially treated, polyester powder-coated sheet metal to ensure superior rust and corrosion resistance.

UV Version : at the upper part, there are the louver (it is orientable and can be closed again for sizes 22; 32; 42 and 50; flat and fixed for sizes 62 and 82), made from thermoplastic material to distribute air, and the door to access the control panel. With the orientable louver fully closed, the tripping of the microswitch stops ventilation, thus interrupting any

further heat exchange with the environment. The casing also features a thermoplastic air recirculation louver at the front.

ELECTRIC FAN ASSEMBLY

It consists of double suction radial fans with lengthways blades to obtain a high air flow with a low number of revs. The electrical motor, protected against overloading, has three speeds with the running capacitor always on, directly coupled with the fans and cushioned with flexible supports. The FHX UVPO version is equipped with a boosted motor set to operate at 7 speeds (3 of which may be selected).

BEARING STRUCTURE

Made of galvanised sheet metal of an adequate thickness. Hole in the back for wall mounting. A fan cover panel is available for front-mounted ceiling units. Each unit is equipped with a condensate collection tray.

CONDENSATE DRAIN

Every device is fitted with a tray for collecting condensation, with a connection for draining condensation produced by the unit in cooling mode.

PLUMBING CONNECTIONS

The connections, located on the left hand side, are female. The coil may also be rotated.

GERMICIDAL LAMP

Germicidal lamp that emits UVC rays. This lamp has a one-year life span; after that time, it should be replaced with a similar lamp. The lamp serves to prevent mould from forming in the fan coil, to eliminate microbiological contamination and to avoid its spread into the room. The UVC radiation emitted by the lamp destroys the main cellular DNA and RNA.

The immediate effect is that cells cannot reproduce and are killed; therefore, the risk of airborne-transmitted infections is reduced up to 90%.

Germicidal lamps emitting UVC rays installed in the fan coils can prevent:

- TB conversions within healthcare facilities.
- Legionnaire's disease.
- Microorganisms in the discharge circuits.
- Contaminated filters or overpressure.
- Spread of infections.

SELECTION CRITERIA

Models with universal cabinet (UV) feature a front intake and can be mounted either vertically on a wall or horizontally on the ceiling.

Wall/ceiling-mounting (UVP and UVPO) versions, without protective cabinet and with intake at the bottom, can be installed either vertically or horizontally. In case of ducted installations where pressure drops in the ducts are considerable, the UVPO model (with boosted multi-speed motors) enables to have the effective pressure needed to guarantee a correct air flow rate.

The UVP and UVPO models are available with 3- and 4-row coils.

The UV model has to be combined with a control panel to be installed internally or externally. Consult the characteristics and compatibility of the control panels supplied as accessories.

The UVP and UVPO models have to be combined with a control panel to be installed externally. Consult the characteristics and compatibility of the control panels supplied as accessories.

The control panels can control a network of fan coils if they are used in combination with the interface cards SIT3 and SIT5 supplied as accessories.

The main technical data of the FHX range are summarised in the tables.

The total and sensible cooling capacities yielded at maximum speed according to the temperature and thermal head of the incoming water, the air temperature with dry bulb or wet bulb for sensible yield and total yield respectively for models with a 3-row coil are shown in the table. Performances at medium and minimum speeds can be obtained by multiplying the values in the table

by the correction factors indicated; for 4-row coil models, by multiplying the values in the table by the correction factors indicated for each speed.

Pressure drops on the water side for 3- and 4-row coils respectively are shown in the graphs.

The correction factors when the unit operates with glycol water for cooling and heating function modes are shown in the graphs in percentages of glycol of 10%, 20% and 35%.

The heating capacity yielded by the 3- and 4-row coils according to the water flow rate and the difference in temperature between the incoming water and the incoming air is represented in a graph and it refers to the maximum speed. Performances at medium and minimum speeds can be obtained by multiplying the values obtained from the graph at maximum speed by the correction factors indicated.

For the ducted wall/ceiling-mounting models (UVP and UVPO), the performances described before must be considered as referring to air flow rates equal to those corresponding to the (UV) models at maximum speed (rated capacities).

The pressure for the wall/ceiling-mounting models according to the air flow rate and the fan speed are shown as a table; the curves show each speed.

For scaling the ducted wall/ceiling-mounting models, it is advisable to proceed as follows: choose the size that given a normal flow rate has a power immediately above that required; afterwards, mark out the curve of the duct pressure drops on the rate-pressure diagram related to the machine in ques-

tion in order to individualise the points of machine operation at the different speeds. Based on the capacity values of these points, you will obtain the correction factors that help calculate the capacity yielded given the actual conditions of air flow rate. For multi-speed models, this procedure helps to suitable choose the speeds to be set.

The pressure and sound power levels of fan coils at the different speeds are shown in separated tables for 3- and 4-row coils models. For the ducted wall/ceiling models, the sound power level is expressed according to the air flow rate and pressure, and represented as graphs.

There is a wide range of accessories for FHX fan coils, sometimes some of them cannot be used at the same time; check that the accessories are compatible with the fan coil chosen. The manual shows the description of each accessory plus a drawing and its compatibility.

The installation information is included in the manuals supplied together with each fan coil or its accessory. This manual is limited to provide general information in order to obtain a correct installation; it also contains drawings with fan coil dimensions and the wiring diagrams with the connections to control panels.

SYSTEM CONFIGURATIONS FOR FHX FAN COILS

Key:

- SW Water temperature sensor
- VCF Solenoid valve (Heating / Cooling)
- SA SA
- V3,V2,V1 Room temperature sensor
- Maximum, Medium or Minimum fan speed

English

System with 2 pipes, without water sensor

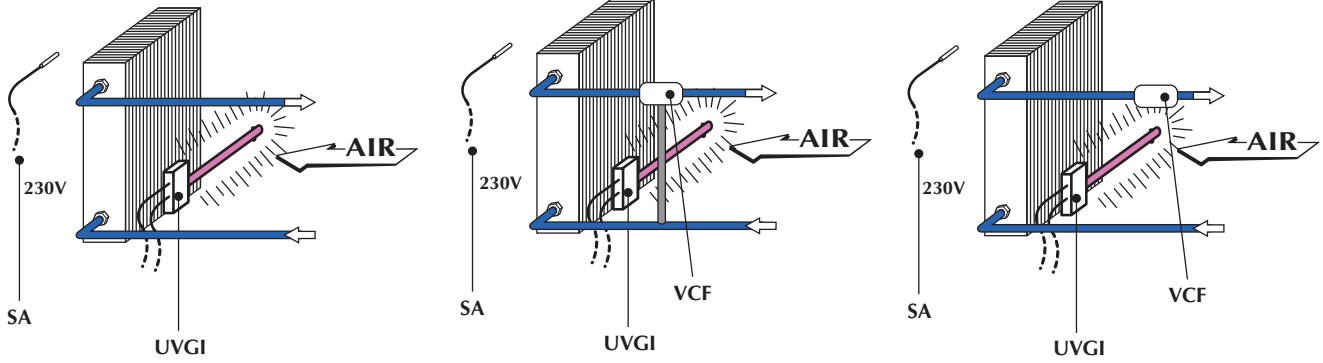

System with 2 pipes, with water sensor

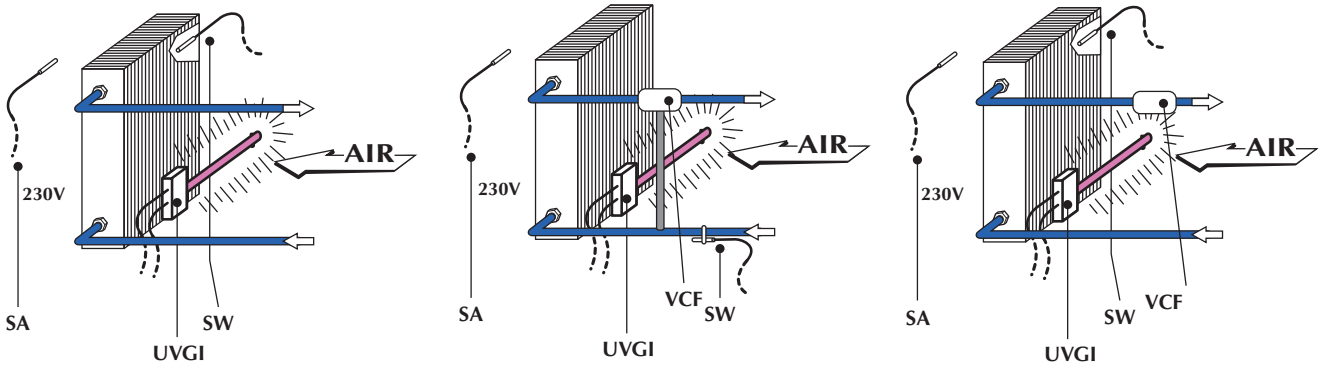

TECHNICAL DATA

FHX UV - UVP with a 3-row coil

Mod.		FHX 22	FHX 32	FHX 42	FHX 50	FHX 62	FHX 82
Heating							
Heating capacity	W (max.)	3400	4975	7400	8620	12920	15140
	W (med.)	2700	4085	6415	7530	10940	13350
	W (min.)	1915	3380	5115	5420	8330	10770
Heating capacity * (water inlet 50°C)	W (E)	2100	3160	4240	4900	6460	7990
Water flow rate	l/h	292	427	636	741	1110	1300
Water pressure drops	kPa	6,3	14,2	14,1	14,2	14,8	19,8
Cooling							
Total cooling capacity	W (max.) (E)	1500	2210	3400	4190	4860	7420
	W (med.)	1330	2055	2800	3640	4660	5500
	W (min.)	1055	1570	2310	2840	3950	4710
Sensible cooling capacity	W (max.) (E)	1240	1750	2760	3000	3980	5680
	W (med.)	1055	1540	2115	2750	3510	4250
	W (min.)	755	1100	1635	2040	2825	3450
Water flow rate	l/h	258	380	585	721	836	1276
Water pressure drops	kPa (E)	5,8	16,6	14,3	19,3	11,6	13,5
Air flow rate	m ³ /h (max.)	290	450	600	720	920	1140
	m ³ /h (med.)	220	350	460	600	720	930
	m ³ /h (min.)	140	260	330	400	520	700
Number of fans		1	2	2	2	3	3
♪ Sound pressure	dB (A) (max.)	41,5	39,5	42,5	47,5	48,5	53,5
	dB (A) (med.)	34,5	32,5	35,5	42,5	42,5	48,5
	dB (A) (min.)	22,5	25,5	28,5	33,5	33,5	41,5
Sound power	dB (A) (max.) (E)	50	48	51	56	57	62
	dB (A) (med.) (E)	43	41	44	51	51	57
	dB (A) (min.) (E)	31	34	37	42	42	50
Water content	l	0,79	1,11	1,48	1,48	2,52	2,52
Max. motor power	W (E)	50	69	82	92	182	206
Max. input current	A	0,24	0,33	0,4	0,47	0,84	0,93
3R Coil connections	ø	1/2"	1/2"	3/4"	3/4"	3/4"	3/4"
1R Coil connections	ø	1/2"	1/2"	1/2"	1/2"	1/2"	1/2"

English

Electrical power supply = 230V ~ 50Hz

(E) = EUROVENT certified performances



Performance values refer to the following conditions:

♪ Sound pressure measured in semi-reverberating chamber, 85m³, and with reverberation time Tr = 0.5s.

Cooling:

- room air temperature 27°C D.B., 19°C W.B.;
- maximum speed:
 - water inlet temperature 7°C; Δt water 5°C.
- medium and minimum speed:
 - water inlet temperature 7°C;
 - water flow rate as at maximum speed.

Heating:

- room air temperature 20°C D.B.;
- maximum speed:
 - water inlet temperature 70°C; Δt water 10°C.
- medium and minimum speed:
 - water inlet temperature 70°C;
 - water flow rate as at maximum speed.
- maximum speed (water inlet 50°C):
 - water inlet temperature 50°C;
 - water flow rate as for cooling operation.

TECHNICAL DATA

FHX UVPO with a 3-row coil

Mod.		FHX 22	FHX 32	FHX 42	FHX 50	FHX 62	FHX 82
Heating							
Heating capacity	W (max.)	3400	4975	7400	8620	12920	15140
	W (med.)	2700	4085	6415	7530	10940	13350
	W (min.)	1915	3380	5115	5420	8330	10770
Heating capacity * (water inlet 50°C)	W (E)	2100	3160	4240	4900	6460	7990
Water flow rate	l/h	292	427	636	741	1110	1300
Water pressure drops	kPa	6,3	14,2	14,1	14,2	14,8	19,8
Cooling							
Total cooling capacity	W (max.) (E)	1500	2210	3400	4190	4860	7420
	W (med.)	1330	2055	2800	3640	4660	5500
	W (min.)	1055	1570	2310	2840	3950	4710
Sensible cooling capacity	W (max.) (E)	1240	1750	2760	3000	3980	5680
	W (med.)	1055	1540	2115	2750	3510	4250
	W (min.)	755	1100	1635	2040	2825	3450
Water flow rate	l/h	258	380	585	721	836	1276
Water pressure drops	kPa (E)	5,8	16,6	14,3	19,3	11,6	13,5
Air flow rate	m ³ /h (max.)	290	450	600	720	920	1140
	m ³ /h (med.)	220	350	460	600	720	930
	m ³ /h (min.)	140	260	330	400	520	700
Number of fans		1	2	2	2	3	3
♪ Sound pressure	dB (A) (max.)	41,5	39,5	42,5	47,5	48,5	53,5
	dB (A) (med.)	34,5	32,5	35,5	42,5	42,5	48,5
	dB (A) (min.)	22,5	25,5	28,5	33,5	33,5	41,5
Sound power	dB (A) (max.) (E)	50	48	51	56	57	62
	dB (A) (med.) (E)	43	41	44	51	51	57
	dB (A) (min.) (E)	31	34	37	42	42	50
Water content	l	0,79	1,11	1,48	1,48	2,52	2,52
Max. motor power	W	79	122	136	107	197	235
Max. input current	A	0,37	0,57	0,63	0,48	0,92	1,06
3R Coil connections	ø	1/2"	1/2"	3/4"	3/4"	3/4"	3/4"
1R Coil connections	ø	1/2"	1/2"	1/2"	1/2"	1/2"	1/2"

English

Electrical power supply = 230V ~ 50Hz

(E) = EUROVENT certified performances



Performance values refer to the following conditions:

♪ Sound pressure measured in semi-reverberating chamber, 85m³, and with reverberation time Tr = 0.5s.

Cooling:

- room air temperature 27°C D.B., 19°C W.B.;
- maximum speed:
 - water inlet temperature 7°C; Δt water 5°C.
- medium and minimum speed:
 - water inlet temperature 7°C;
 - water flow rate as at maximum speed.

Heating:

- room air temperature 20°C D.B.;
- maximum speed:
 - water inlet temperature 70°C; Δt water 10°C.
- medium and minimum speed:
 - water inlet temperature 70°C;
 - water flow rate as at maximum speed.
- maximum speed (water inlet 50°C):
 - water inlet temperature 50°C;
 - water flow rate as for cooling operation.

TECHNICAL DATA

FHX UVP with a 4-row coil

Mod.		FHX 24	FHX 34	FHX 44	FHX 54	FHX 64	FHX 84
Heating							
Heating capacity	W (max.)	3950	5850	8600	10100	14300	17100
	W (med.)	3200	4850	6930	8760	11500	14420
	W (min.)	2200	3850	5200	6240	8500	11200
Heating capacity * (water inlet 50°C)	W (E)	2320	3550	5250	6100	7810	10400
Water flow rate	l/h	340	503	740	869	1230	1471
Water pressure drops	kPa	4	8	21	22	22	30
Cooling							
Total cooling capacity	W (max.) (E)	1730	2800	4450	4970	6350	8600
	W (med.)	1500	2450	3780	4770	5520	7600
	W (min.)	1150	2050	2970	3620	4500	6270
Sensible cooling capacity	W (max.) (E)	1380	2130	3300	3540	5030	5780
	W (med.)	1140	1789	2722	3101	4195	5016
	W (min.)	828	1441	2079	2281	3330	4013
Water flow rate	l/h	297	482	765	855	1092	1479
Water pressure drops	kPa (E)	3	9	19,2	25,9	13	22
Air flow rate	m ³ /h (max.)	290	450	600	720	920	1140
	m ³ /h (med.)	220	350	460	600	720	930
	m ³ /h (min.)	140	260	330	400	520	700
Number of fans		1	2	2	2	3	3
♪ Sound pressure	dB (A) (max.)	42,5	39,5	46,5	47,5	48,5	52,5
	dB (A) (med.)	37,5	32,5	41,5	44,5	42,5	48,5
	dB (A) (min.)	26,5	27,5	32,5	35,5	35,5	42,5
Sound power	dB (A) (max.) (E)	51	48	55	56	57	61
	dB (A) (med.) (E)	46	41	50	53	51	57
	dB (A) (min.) (E)	35	36	41	44	44	51
Water content	l	1	1,5	1,9	1,9	3,4	3,4
Max. motor power	W (E)	50	69	82	92	182	206
Max. input current	A	0,24	0,33	0,4	0,47	0,84	0,93
Coil connections 4R	ø	3/4"	3/4"	3/4"	3/4"	3/4"	3/4"

English

Electrical power supply = 230V ~ 50Hz

(E) = EUROVENT certified performances



Performance values refer to the following conditions:

♪ Sound pressure measured in semi-reverberating chamber, 85m³, and with reverberation time Tr = 0.5s.

Cooling:

- room air temperature 27°C D.B., 19°C W.B.;
- maximum speed:
 - water inlet temperature 7°C; Δt water 5°C.
- medium and minimum speed:
 - water inlet temperature 7°C;
 - water flow rate as at maximum speed.

Heating:

- room air temperature 20°C D.B.;
- maximum speed:
 - water inlet temperature 70°C; Δt water 10°C.
- medium and minimum speed:
 - water inlet temperature 70°C;
 - water flow rate as at maximum speed.
- maximum speed (water inlet 50°C):
 - water inlet temperature 50°C;
 - water flow rate as for cooling operation.

TECHNICAL DATA

FHX UVPO with a 4-row coil

English

Mod.		FHX 24	FHX 34	FHX 44	FHX 54	FHX 64	FHX 84
Heating							
Heating capacity	W (max.)	3950	5850	8600	10100	14300	17100
	W (med.)	3200	4850	6930	8760	11500	14420
	W (min.)	2200	3850	5200	6240	8500	11200
Heating capacity * (water inlet 50°C)	W (E)	2320	3550	5250	6100	7810	10400
Water flow rate	l/h	340	503	740	869	1230	1471
Water pressure drops	kPa	4	8	21	22	22	30
Cooling							
Total cooling capacity	W (max.) (E)	1730	2800	4450	4970	6350	8600
	W (med.)	1500	2450	3780	4770	5520	7600
	W (min.)	1150	2050	2970	3620	4500	6270
Sensible cooling capacity	W (max.) (E)	1380	2130	3300	3540	5030	5780
	W (med.)	1140	1789	2722	3101	4195	5016
	W (min.)	828	1441	2079	2281	3330	4013
Water flow rate	l/h	297	482	765	855	1092	1479
Water pressure drops	kPa (E)	3	9	19,2	25,9	13	22
Air flow rate	m ³ /h (max.)	290	450	600	720	920	1140
	m ³ /h (med.)	220	350	460	600	720	930
	m ³ /h (min.)	140	260	330	400	520	700
Number of fans		1	2	2	2	3	3
Sound pressure	dB (A) (max.)	49,5	44	50	50,5	53,5	55,5
Sound pressure	dB (A) (max.)	58	52,5	58,5	59	62	64
Water content	l	1	1,5	1,9	1,9	3,4	3,4
Max. motor power	W (E)	79	122	136	107	197	235
Max. input current	A	0,37	0,57	0,63	0,48	0,92	1,06
Coil connections 4R	ø	3/4"	3/4"	3/4"	3/4"	3/4"	3/4"

Electrical power supply = 230V ~ 50Hz

(E) = EUROVENT certified performances



Performance values refer to the following conditions:

♪ Sound pressure measured in semi-reverberating chamber, 85m³, and with reverberation time Tr = 0.5s.

Cooling:

- room air temperature 27°C D.B., 19°C W.B.;
- maximum speed:
 - water inlet temperature 7°C; Δt water 5°C.
- medium and minimum speed:
 - water inlet temperature 7°C;
 - water flow rate as at maximum speed.

Heating:

- room air temperature 20°C D.B.;
- maximum speed:
 - water inlet temperature 70°C; Δt water 10°C.
- medium and minimum speed:
 - water inlet temperature 70°C;
 - water flow rate as at maximum speed.
- maximum speed (water inlet 50°C):
 - water inlet temperature 50°C;
 - water flow rate as for cooling operation.

OPERATING LIMITS

Maximum water input temperature 80 °C
Maximum operating pressure 8 bar
Operating voltage 230V(±10%) ~ 50Hz
Room temperature 0-45°C
Humidity of the air <85% U.R.

Output limits (3-row coil):

MODEL	FHX	22	32	42	50	62	82
Minimum output	[l/h]	100	100	150	150	300	300
Maximum output	[l/h]	750	750	1100	1100	2200	2200

Output limits (4-row coil):

MODEL	FHX	24	34	44	54	64	84
Minimum output	[l/h]	150	150	150	150	300	300
Maximum output	[l/h]	1100	1100	1100	1100	2200	2200

Minimum medium water temperature

To avoid condensate forming on the external structure of the unit while the fan is functioning, the medium water temperature must not be lower than the limits shown in the table below, that depend on the thermohygrometric condition of the air in the room.
 These limits refer to unit operating with fan at minimum speed.

In the case of a prolonged situation with the fan off and the passage of cold water in the coil, condensation can form on the outside of the unit, so it is recommended that a 3-way valve accessory be fitted.

MINIMUM MEDIUM WATER TEMPERATURE

		Room air temperature with dry bulb °C					
		21	23	25	27	29	31
Temperature with wet bulb of air in the room °C	15	3	3	3	3	3	3
	17	3	3	3	3	3	3
	19	3	3	3	3	3	3
	21	6	5	4	3	3	3
	23	-	8	7	6	5	5

COOLING CAPACITY

FHX 22

English

Water temp. Inlet [°C]		TOTAL COOLING CAPACITY [W] Air temperature - wet bulb [°C]					SENSIBLE COOLING CAPACITY [W] Air temperature - dry bulb [°C]						
		Δt	15	17	19	21	23	21	23	25	27	29	31
5	3		1238	1731	2254	–	–	1065	1253	1434	1590	1743	1891
	4		1110	1579	2090	2613	3163	973	1162	1350	1512	1669	1823
	5		948	1372	1893	2440	3003	864	1048	1236	1430	1594	1751
	6		866	1167	1677	2250	2826	814	955	1124	1322	1511	1673
	7		–	1049	1436	2028	2631	768	907	1033	1207	1407	1591
6	3		1085	1555	2086	2613	–	980	1164	1352	1511	1667	1814
	4		963	1387	1917	2440	2994	875	1068	1252	1432	1591	1745
	5		837	1198	1701	2258	2826	786	955	1143	1334	1514	1672
	6		779	1015	1478	2063	2640	742	882	1038	1229	1422	1594
	7		–	946	1247	1811	2436	698	840	969	1119	1314	1510
7	3		948	1372	1893	2440	–	885	1066	1262	1432	1589	1736
	4		841	1207	1719	2258	2817	783	977	1165	1350	1513	1666
	5		750	1033	1500	2072	2640	719	869	1056	1240	1432	1595
	6		707	908	1280	1841	2445	673	814	953	1139	1326	1513
	7		–	847	1107	1597	2232	627	766	905	1036	1223	1419
8	3		837	1198	1701	2258	–	794	983	1164	1349	1508	1662
	4		748	1046	1512	2072	2631	701	891	1073	1260	1430	1590
	5		683	901	1311	1862	2449	649	786	971	1149	1340	1514
	6		–	817	1119	1625	2245	603	742	882	1049	1235	1430
	7		–	–	994	1390	1997	558	696	839	967	1129	1327
9	3		750	1033	1527	2072	–	714	890	1079	1261	1429	1582
	4		671	907	1314	1878	2440	625	793	984	1166	1350	1511
	5		616	783	1137	1640	2250	580	717	878	1061	1250	1434
	6		–	738	966	1420	2019	534	673	813	966	1147	1337
	7		–	–	889	1198	1762	487	627	766	904	1047	1230
10	3		683	901	1311	1862	2449	633	799	986	1163	1347	1505
	4		593	796	1134	1652	2241	554	711	897	1073	1260	1431
	5		–	713	977	1433	2037	510	648	790	979	1159	1345
	6		–	–	858	1222	1780	464	603	741	884	1062	1245
	7		–	–	–	1052	1542	415	558	696	840	968	1143
11	3		–	782	1137	1640	2250	551	719	893	1078	1257	1424
	4		–	716	978	1433	2032	486	629	801	986	1167	1349
	5		–	646	854	1238	1795	441	579	717	888	1067	1252
	6		–	–	767	1061	1555	393	534	673	812	975	1151
	7		–	–	–	933	1329	342	487	627	764	904	1058
12	3		–	713	977	1433	2037	467	638	804	988	1162	1343
	4		–	637	854	1247	1801	416	554	720	901	1075	1259
	5		–	–	753	1073	1564	370	510	648	799	985	1161
	6		–	–	701	918	1350	322	464	603	741	889	1070
	7		–	–	–	840	1143	266	415	558	696	836	974
13	3		–	646	854	1238	1795	392	556	723	896	1078	1253
	4		–	–	762	1058	1561	346	485	638	809	989	1165
	5		–	–	678	921	1350	299	440	578	720	896	1070
	6		–	–	–	806	1155	246	393	534	671	812	983
	7		–	–	–	–	988	181	342	487	627	764	902

NB: The yield values in bold type indicate the nominal value.

If sensible yield values are above the total output, this means that cooling is carried out without dehumidification. If this occurs, take into consideration only the sensible yield values.

The cooling capacities yielded shown in the table must be multiplied by the following factors:

MODEL		FHX 22	FHX 24
Maximum speed	total power	1.00	1.15
	sensible power	1.00	1.11
Medium speed	total power	0.89	1.00
	sensible power	0.85	0.92
Minimum speed	total power	0.70	0.77
	sensible power	0.61	0.67

COOLING CAPACITY

FHX 32

Water temp. Inlet [°C]		TOTAL COOLING CAPACITY [W] Air temperature - wet bulb [°C]					SENSIBLE COOLING CAPACITY [W] Air temperature - dry bulb [°C]					
		15	17	19	21	23	21	23	25	27	29	31
5	3	1303	1866	2512	3148	–	1134	1368	1612	1817	2004	2184
	4	1618	2281	2921	–	–	1351	1604	1851	2055	2253	2438
	5	1415	2026	2728	3419	–	1231	1485	1750	1973	2176	2371
	6	1231	1793	2502	3228	3968	1088	1360	1623	1881	2090	2292
	7	1064	1556	2246	3010	3770	997	1222	1493	1753	2001	2210
6	3	1587	2241	–	–	–	1347	1593	1831	2029	2220	2409
	4	1407	2013	2693	–	–	1230	1477	1733	1954	2153	2340
	5	1236	1780	2491	3189	3924	1103	1366	1623	1867	2076	2272
	6	1056	1552	2219	2984	3732	974	1236	1494	1755	1989	2193
	7	960	1332	1964	2759	3528	906	1104	1368	1630	1895	2106
7	3	1363	1989	–	–	–	1219	1479	1726	1928	2120	2313
	4	1205	1758	2456	3138	–	1095	1355	1604	1849	2054	2246
	5	1069	1552	2210	2947	3681	987	1240	1488	1750	1973	2174
	6	939	1341	1956	2733	3489	878	1114	1377	1630	1884	2090
	7	871	1152	1705	2456	3272	817	997	1248	1501	1759	2004
8	3	1174	1723	2403	–	–	1084	1349	1593	1827	2022	2212
	4	1056	1523	2193	2895	–	990	1233	1476	1744	1950	2149
	5	942	1337	1938	2693	3438	878	1114	1372	1625	1868	2072
	6	841	1161	1710	2448	3228	785	990	1255	1501	1755	1989
	7	–	1012	1490	2170	2997	727	906	1120	1382	1636	1896
9	3	1042	1475	2162	–	–	981	1221	1477	1722	1921	2115
	4	952	1320	1912	2649	–	881	1114	1357	1616	1848	2046
	5	843	1152	1688	2413	3182	764	1001	1248	1492	1752	1970
	6	–	1009	1472	2158	2959	695	881	1128	1386	1632	1882
	7	–	911	1275	1881	2693	635	817	1003	1263	1261	1771
10	3	942	1264	1872	–	–	875	1089	1348	1591	1819	2013
	4	847	1131	1653	2386	3112	774	997	1240	1491	1743	1948
	5	–	1014	1447	2113	2914	663	891	1134	1376	1624	1864
	6	–	900	1271	1864	2680	622	785	1008	1266	1513	1755
	7	–	–	1104	1623	2378	542	727	906	1145	1389	1638
11	3	839	1095	1600	2320	–	769	983	1224	1474	1716	1914
	4	–	1007	1420	2078	2851	661	891	1109	1359	1615	1844
	5	–	909	1258	1832	2636	574	778	1010	1254	1503	1749
	6	–	–	1102	1618	2355	512	695	895	1148	1392	1634
	7	–	–	963	1398	2078	448	635	817	1015	1274	1524
12	3	–	992	1363	2035	–	661	880	1091	1349	1587	1813
	4	–	904	1212	1793	2579	546	783	1003	1242	1491	1737
	5	–	–	1087	1583	2316	483	667	902	1141	1379	1622
	6	–	–	971	1390	2030	419	605	788	1021	1274	1517
	7	–	–	–	1209	1789	347	542	727	911	1159	1405
13	3	–	891	1172	1739	–	552	774	987	1210	1472	1709
	4	–	–	1063	1534	2267	452	672	898	1114	1359	1610
	5	–	–	971	1352	1995	391	574	792	1019	1260	1503
	6	–	–	–	1198	1754	321	512	695	911	1158	1394
	7	–	–	–	1042	1534	238	448	635	817	1033	1291

NB: The yield values in bold type indicate the nominal value.

If sensible yield values are above the total output, this means that cooling is carried out without dehumidification. If this occurs, take into consideration only the sensible yield values.

The cooling capacities yielded shown in the table must be multiplied by the following factors:

MODEL		FHX 32	FHX 34
Maximum speed	total power	1.00	1.17
	sensible power	1.00	1.12
Medium speed	total power	0.86	1.02
	sensible power	0.81	0.94
Minimum speed	total power	0.65	0.85
	sensible power	0.58	0.76

COOLING CAPACITY

FHX 42

Water temp. Inlet [°C]		TOTAL COOLING CAPACITY [W] Air temperature - wet bulb [°C]					SENSIBLE COOLING CAPACITY [W] Air temperature - dry bulb [°C]						
		Δt	15	17	19	21	23	21	23	25	27	29	31
5	3		2871	–	–	–	–	2336	2730	3088	3401	3715	–
	4		2491	3516	4551	–	–	2149	2550	2942	3279	3602	3907
	5		2156	3110	4241	5329	–	1920	2332	2752	3134	3468	3791
	6		1808	2717	3825	5010	6191	1648	2113	2530	2955	3320	3653
	7		1602	2278	3368	4635	5854	1544	1850	2298	2737	3155	3507
6	3		2491	3497	–	–	–	2131	2542	2918	3240	3552	–
	4		2166	3103	4194	–	–	1939	2349	2755	3112	3437	3749
	5		1879	2730	3832	4963	6126	1706	2143	2554	2962	3303	3628
	6		1563	2343	3426	4626	5816	1496	1908	2337	2754	3150	3489
	7		1457	1924	2962	4204	5460	1402	1685	2094	2528	2951	3339
7	3		2146	3071	–	–	–	1929	2336	2730	3076	3393	3702
	4		1882	2742	3825	4898	–	1740	2160	2553	2941	3275	3592
	5		1621	2375	3400	4579	5751	1523	1944	2343	2760	3133	3465
	6		1415	2014	2987	4223	5423	1355	1679	2138	2558	2960	3322
	7		1321	1689	2556	3471	5048	1260	1544	1878	2338	2754	3163
8	3		1850	2704	3761	–	–	1740	2136	2539	2909	3228	3540
	4		1647	2382	3381	4523	–	1564	1948	2357	2754	3108	3429
	5		1482	2040	3013	4185	5357	1334	1751	2160	2561	2958	3298
	6		1279	1737	2601	3748	5010	1216	1507	1940	2353	2761	3151
	7		–	1518	2195	3297	4616	1118	1402	1695	2140	2559	2975
9	3		1644	2324	3342	–	–	1571	1934	2334	2739	3064	3379
	4		1482	2033	2987	4128	–	1388	1753	2166	2554	2936	3267
	5		1266	1782	2588	3741	4954	1169	1557	1962	2369	2758	3131
	6		–	1515	2233	3297	4588	1074	1355	1733	2172	2565	2964
	7		–	1386	1859	2846	4109	976	1260	1540	1932	2362	2760
10	3		1482	1995	2936	–	–	1398	1746	2135	2536	2899	3215
	4		1312	1769	2581	3683	4869	1203	1581	1961	2357	2750	3100
	5		–	1563	2246	3284	4532	1027	1368	1772	2169	2560	2956
	6		–	1350	1924	2846	4109	932	1214	1534	1977	2380	2762
	7		–	–	1615	2446	3619	831	1118	1402	1718	2169	2573
11	3		1320	1727	2517	3625	–	1224	1577	1938	2333	2732	3052
	4		–	1579	2195	3245	4448	1010	1405	1767	2168	2547	2929
	5		–	1392	1927	2852	4083	885	1179	1584	1990	2373	2757
	6		–	–	1647	2465	3613	788	1074	1361	1770	2186	2570
	7		–	–	1450	2098	3155	684	976	1260	1547	1966	2373
12	3		–	1566	2149	3149	–	1047	1407	1753	2136	2529	2883
	4		–	1412	1901	2800	4012	841	1226	1598	1984	2356	2741
	5		–	–	1669	2433	3580	744	1027	1402	1794	2177	2561
	6		–	–	1466	2117	3142	642	932	1213	1574	1999	2385
	7		–	–	–	1789	2710	529	831	1118	1402	1768	2189
13	3		–	1405	1850	2730	–	863	1233	1584	1945	2329	2717
	4		–	–	1669	2375	3535	698	1037	1422	1780	2172	2545
	5		–	–	1502	2104	3103	600	885	1206	1604	2003	2374
	6		–	–	–	1824	2691	491	788	1072	1382	1808	2195
	7		–	–	–	1544	2317	359	684	976	1260	1564	2004

NB: The yield values in bold type indicate the nominal value.

If sensible yield values are above the total output, this means that cooling is carried out without dehumidification. If this occurs, take into consideration only the sensible yield values.

The cooling capacities yielded shown in the table must be multiplied by the following factors:

MODEL		FHX 42	FHX 44
Maximum speed	total power	1.00	1.31
	sensible power	1.00	1.20
Medium speed	total power	0.82	1.11
	sensible power	0.77	0.99
Minimum speed	total power	0.68	0.87
	sensible power	0.59	0.75

COOLING CAPACITY

FHX 50

Water temp. Inlet [°C]		TOTAL COOLING CAPACITY [W] Air temperature - wet bulb [°C]					SENSIBLE COOLING CAPACITY [W] Air temperature - dry bulb [°C]					
		15	17	19	21	23	21	23	25	27	29	31
5	3	3542	–	–	–	–	2624	2952	3296	3632	–	–
	4	3227	4260	5468	–	–	2461	2810	3145	3500	3836	4164
	5	2912	3892	5083	6406	–	2284	2643	2999	3343	3704	4039
	6	2588	3516	4663	6011	7451	2064	2467	2831	3185	3545	3896
	7	2246	3130	4234	5565	7043	1755	2251	2646	3015	3369	3740
6	3	3170	–	–	–	–	2448	2788	3113	3458	3791	–
	4	2885	3848	5031	–	–	2290	2642	2980	3326	3663	3989
	5	2605	3498	4628	5960	–	2096	2470	2829	3168	3523	3861
	6	2307	3139	4225	5539	6979	1848	2290	2656	3013	3356	3720
	7	1983	2789	3813	5083	6546	1537	2053	2471	2841	3194	3556
7	3	2833	3778	–	–	–	2278	2623	2941	3280	3619	–
	4	2579	3454	4575	–	–	2105	2472	2809	3139	3486	3819
	5	2329	3130	4190	5486	–	1892	2301	2657	3000	3343	3690
	6	2062	2806	3796	5039	6495	1618	2104	2483	2838	3182	3541
	7	1721	2474	3402	4593	6037	1355	1827	2292	2670	3020	3370
8	3	2535	3376	–	–	–	2090	2448	2786	3096	3443	3772
	4	2325	3078	4129	5390	–	1900	2298	2642	2975	3307	3647
	5	2075	2789	3791	4996	6406	1675	2119	2483	2829	3165	3516
	6	1817	2496	3393	4558	5986	1367	1892	2308	2666	3006	3357
	7	–	2189	3034	4137	5503	–	1581	2102	2496	2854	3195
9	3	2299	3008	4024	–	–	1884	2282	2612	2931	3262	3598
	4	2097	2745	3700	4908	–	1690	2122	2478	2808	3129	3468
	5	1861	2491	3358	4505	5909	1448	1917	2318	2659	2994	3329
	6	–	2229	3017	4094	5468	1147	1666	2127	2502	2845	3172
	7	–	1940	2693	3700	4987	–	1367	1884	2320	2683	3024
10	3	2075	2675	3603	–	–	1678	2093	2449	2775	3079	3421
	4	1874	2456	3279	4435	–	1476	1917	2308	2644	2967	3291
	5	–	2237	2982	4032	5398	1210	1702	2138	2492	2828	3141
	6	–	1992	2684	3665	4926	–	1428	1929	2331	2675	3005
	7	–	–	2386	3279	4479	–	–	1650	2137	2515	2853
11	3	1852	2412	3192	–	–	1469	1892	2288	2606	2916	3240
	4	–	2224	2920	3962	5267	1255	1706	2134	2478	2803	3111
	5	–	2010	2653	3603	4847	951	1481	1941	2332	2662	2979
	6	–	–	2395	3253	4418	–	1174	1706	2154	2513	2836
	7	–	2123	2912	3997	–	v	1400	1932	2342	2693	–
12	3	–	2193	2833	3831	–	1258	1687	2102	2448	2762	3061
	4	–	2001	2605	3507	4733	1025	1493	1929	2316	2641	2955
	5	–	–	2377	3192	4339	–	1251	1727	2157	2500	2823
	6	–	–	2150	2885	3927	–	–	1476	1957	2344	2679
	7	–	–	–	2579	3551	–	–	–	1706	2170	2527
13	6	–	1970	2531	3398	–	1045	1481	1896	2288	2612	2897
	4	–	–	2351	3113	4243	765	1275	1718	2146	2480	2797
	5	–	–	2150	2833	3848	–	992	1509	1957	2343	2660
	6	–	–	–	2561	3489	–	–	1222	1739	2175	2516
	7	–	–	–	2299	3139	–	–	–	1457	1972	2365

NB: The yield values in bold type indicate the nominal value.

If sensible yield values are above the total output, this means that cooling is carried out without dehumidification. If this occurs, take into consideration only the sensible yield values.

The cooling capacities yielded shown in the table must be multiplied by the following factors:

MODEL		FHX 50	FHX54
Maximum speed	total power	1.00	1.26
	sensible power	1.00	1.18
Medium speed	total power	0.87	1.14
	sensible power	0.92	1.03
Minimum speed	total power	0.68	0.86
	sensible power	0.68	0.76

COOLING CAPACITY

FHX 62

Water temp. Inlet [°C]		TOTAL COOLING CAPACITY [W] Air temperature - wet bulb [°C]					SENSIBLE COOLING CAPACITY [W] Air temperature - dry bulb [°C]						
		15	17	19	21	23	21	23	25	27	29	31	
English	5	3	4190	5511	6974	-	-	3490	3981	4464	4949	5415	5861
		4	3725	5018	6500	8084	-	3214	3725	4222	4720	5208	5681
		5	3185	4460	5949	7583	9315	2836	3424	3955	4465	4977	5465
		6	2739	3818	5335	7015	8801	2611	3030	3637	4184	4717	5231
		7	2586	3241	4609	6365	8205	2460	2867	3249	3848	4419	4963
	6	3	3734	5009	6460	-	-	3253	3735	4210	4701	5175	5620
		4	3302	4506	5967	7556	9248	2970	3482	3982	4468	4964	5441
		5	2804	3967	5409	7041	8774	2558	3171	3710	4219	4727	5224
		6	2501	3325	4776	6446	8233	2387	2818	3372	3934	4465	4986
		7	2358	2953	4050	5762	7624	2236	2975	3053	3581	4167	4714
	7	3	3316	4498	5930	-	-	3017	3499	3977	4456	4934	5388
		4	2924	4023	5418	7015	8706	2704	3240	3738	4227	4721	5200
		5	2478	3501	4860	6474	8205	2314	2909	3463	3980	4471	4977
		6	2287	2907	4237	5847	7651	2163	2606	3102	3685	4213	4733
7		-	2693	3492	5149	6988	2012	2460	2869	3304	3913	4453	
8	3	2943	4004	5391	6946	-	2757	3262	3728	4205	4691	5155	
	4	2618	3567	4869	6446	8151	2411	3001	3499	3985	4471	4960	
	5	2394	3083	4330	5874	7637	2089	2616	3216	3729	4233	4731	
	6	2073	2618	3725	5251	7028	1938	2387	2836	3431	3967	4482	
	7	-	2460	3111	4553	6338	1783	2236	2671	3066	3648	4203	
9	3	2655	3544	4833	6392	-	2480	3031	3502	3965	4448	4915	
	4	2339	3149	4349	5855	7569	2099	2742	3266	3742	4226	4714	
	5	2004	2720	3827	5279	7028	1865	2323	2967	3489	3982	4474	
	6	-	2390	3251	4665	6392	1714	2163	2906	3170	3717	4227	
	7	-	-	2813	3976	5688	1558	2012	2455	2867	3382	3955	
10	3	2394	3135	4302	5800	-	2202	2777	3269	3735	4198	4675	
	4	2050	2800	3836	5260	6974	1797	2455	3029	3508	3980	4462	
	5	-	2418	3363	4702	6392	1641	2089	2694	3252	3742	3982	
	6	-	2176	2822	4107	5744	1485	1938	2382	2897	3472	3982	
	7	-	-	2567	3437	5056	1327	1783	2231	2973	3107	3697	
11	3	2125	2800	3790	5204	6866	1914	2498	3043	3506	3957	4433	
	4	-	2520	3380	4693	6352	1598	2158	2777	3278	3746	4208	
	5	-	2125	2962	4153	5744	1417	1865	2382	3005	3514	3986	
	6	-	-	2515	3595	5111	1258	1714	2158	2626	3229	3746	
	7	-	-	2348	2981	4441	1091	1558	2007	2455	2880	3447	
12	3	-	2539	3334	4618	6257	1612	2221	2786	3273	3727	4182	
	4	-	2246	2990	4135	5698	1344	1836	2494	3049	3520	3978	
	5	-	-	2627	3651	5111	1190	1641	2094	2753	3281	3753	
	6	-	-	2278	3139	4506	1027	1485	1936	2382	2972	3504	
	7	-	-	-	2683	3864	845	1327	1783	2231	2674	3188	
13	3	-	2278	2957	4064	5614	1283	1938	2513	3050	3504	3944	
	4	-	-	2683	3632	5064	1116	1566	2202	2806	3293	3744	
	5	-	-	2344	3204	4506	959	1415	1860	2451	3044	3522	
	6	-	-	-	2748	3939	813	1258	1711	2158	2681	3268	
	7	-	-	-	2451	3344	575	1091	1558	2007	2455	2921	

NB: The yield values in bold type indicate the nominal value.

If sensible yield values are above the total output, this means that cooling is carried out without dehumidification. If this occurs, take into consideration only the sensible yield values.

The cooling capacities yielded shown in the table must be multiplied by the following factors:

MODEL		FHX 62	FHX 64
Maximum speed	total power	1.00	1.31
	sensible power	1.00	1.19
Medium speed	total power	0.96	1.14
	sensible power	0.83	0.99
Minimum speed	total power	0.81	0.93
	sensible power	0.67	0.79

COOLING CAPACITY

FHX 82

Water temp. Inlet [°C]		TOTAL COOLING CAPACITY [W] Air temperature - wet bulb [°C]					SENSIBLE COOLING CAPACITY [W] Air temperature - dry bulb [°C]					
		15	17	19	21	23	21	23	25	27	29	31
5	3	5591	7373	–	–	–	4995	5671	6366	7036	7680	8303
	4	4979	6701	8676	10810	0	4612	5326	6023	6722	7409	8055
	5	4320	5975	7952	10144	12453	4127	4927	5664	6367	7082	7760
	6	3553	5167	7131	9381	11749	3569	4400	5232	5983	6715	7440
	7	3291	4225	6243	8503	10985	3346	3939	4689	5556	6331	7069
6	3	4979	6688	–	–	–	4656	5338	6008	6699	7344	7987
	4	4427	6014	7965	10106	–	4262	4990	5672	6373	7073	7735
	5	3815	5315	7212	9401	11729	3710	4576	5313	6019	6732	7428
	6	3217	4549	6405	8597	10985	3248	3978	4879	5643	6357	7085
	7	3008	3782	5517	7696	10164	3032	3658	4291	5193	5969	6718
7	3	4427	6002	7925	–	–	4318	4996	5669	6354	7018	7657
	4	3930	5369	7218	9361	–	3890	4652	5337	6011	6723	7401
	5	3392	4710	7420	8638	10966	3256	4211	4972	5680	6381	7084
	6	2927	3984	5705	7803	10203	2934	3591	4504	5290	6015	6742
	7	2725	3432	4817	6902	9342	2718	3346	3953	4818	5619	6367
8	3	3949	5342	7185	–	–	3950	4670	5337	5999	6679	7324
	4	3526	4763	6486	8611	10887	3480	4310	5009	5681	6364	7056
	5	3210	4159	5773	7830	10183	2852	3815	4624	5337	6022	6740
	6	2645	3473	5033	6997	9381	2621	3248	4115	4938	5668	6380
	7	–	3143	4172	6136	8477	2405	3032	3651	4427	5263	6006
9	3	3566	4724	6432	–	–	3555	4340	5002	5654	6329	6978
	4	3156	4219	5786	7803	10106	3054	3942	4671	5347	6008	6711
	5	2585	3687	5113	7024	9361	2532	3375	4275	4996	5688	6375
	6	–	3096	4414	6230	8503	2308	2934	3674	4588	5320	6032
	7	–	2861	3648	5382	7589	2083	2718	3346	4008	4898	5660
10	3	3210	4192	5719	7723	–	3151	3971	4678	5336	5978	6644
	4	2773	3762	5113	6997	9283	2599	3539	4340	5017	5686	6356
	5	–	3291	4508	6270	8503	2219	2905	3898	4668	5357	6034
	6	–	2780	3875	5503	7642	1995	2621	3271	4219	4984	5694
	7	–	–	3284	4697	6754	1770	2405	3032	3666	4538	5315
11	3	2847	3755	5046	6916	–	2741	3576	4355	4997	5647	6300
	4	–	3392	4522	6230	8450	2136	3114	3986	4692	5357	6000
	5	–	2894	3984	5530	7628	1905	2532	3472	4329	5026	5694
	6	–	–	3405	4831	6808	1679	2308	2934	3808	4650	5351
	7	–	–	2995	4077	5948	1442	2088	2718	3346	4132	4968
12	3	–	3405	4448	6136	–	2323	3181	3994	4679	5326	5953
	4	–	3015	4003	5503	7562	1811	2681	3584	4370	5026	5671
	5	–	–	3553	4871	6781	1589	2219	3017	3971	4704	5369
	6	–	–	2988	4239	6002	1358	1995	2621	3346	4297	5026
	7	–	–	–	3539	5194	1103	1770	2405	3032	3718	4617
13	3	–	3049	3957	5402	7440	1868	2774	3599	4365	4995	5622
	4	–	–	3600	4831	6727	1495	2196	3166	4024	4713	5348
	5	–	–	3176	4293	5988	1270	1905	2554	3547	4372	5038
	6	–	–	–	3728	5275	1025	1679	2308	2949	3915	4691
	7	–	–	–	3156	4535	732	1444	2088	2718	3346	4254

NB: The yield values in bold type indicate the nominal value.

If sensible yield values are above the total output, this means that cooling is carried out without dehumidification. If this occurs, take into consideration only the sensible yield values.

The cooling capacities yielded shown in the table must be multiplied by the following factors:

MODEL		FHX 82	FHX 84
Maximum speed	total power	1.00	1.24
	sensible power	1.00	1.06
Medium speed	total power	0.80	1.10
	sensible power	0.85	1.00
Minimum speed	total power	0.68	0.91
	sensible power	0.69	0.80

HEATING CAPACITY YIELDED WITH A 3-ROW COIL

English

FHX 22

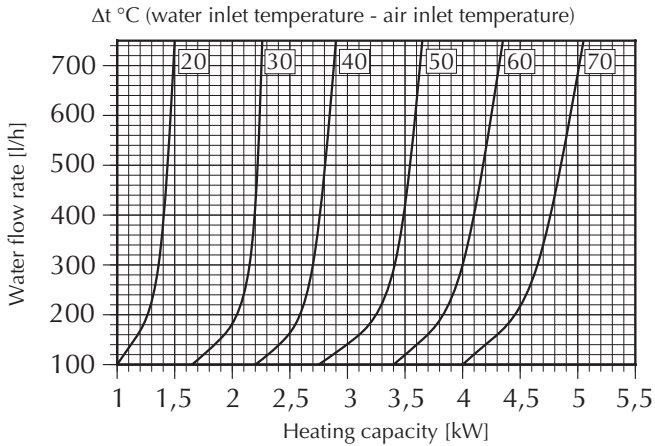

FHX 32

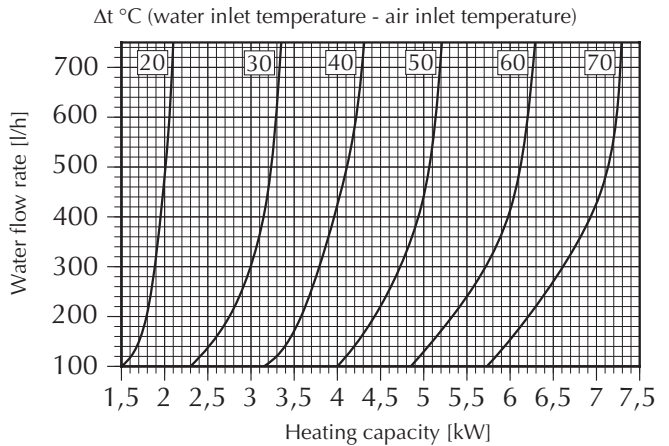

FHX 42

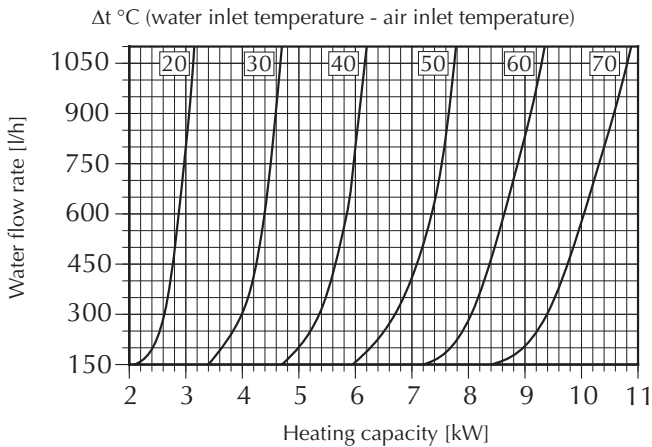

FHX 50

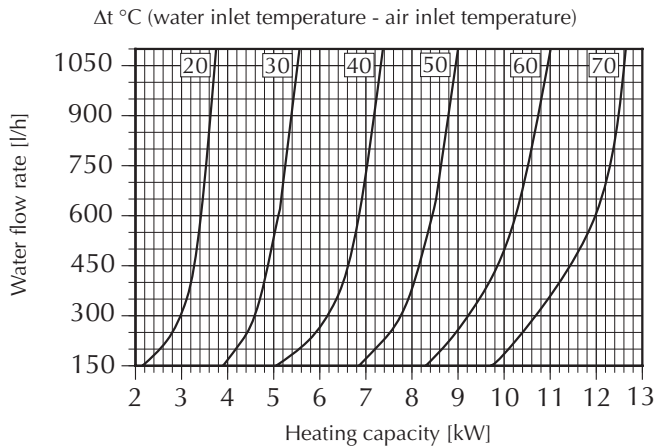

FHX 62

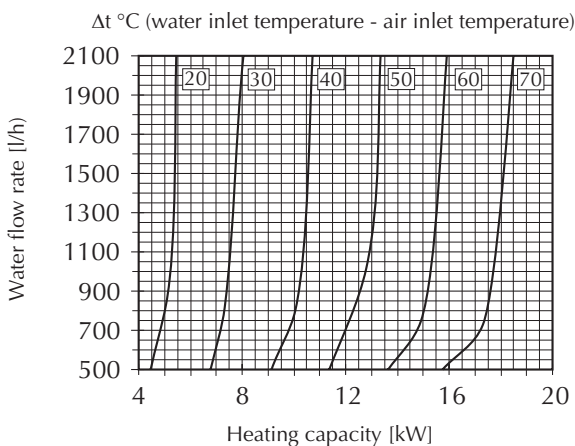

FHX 82

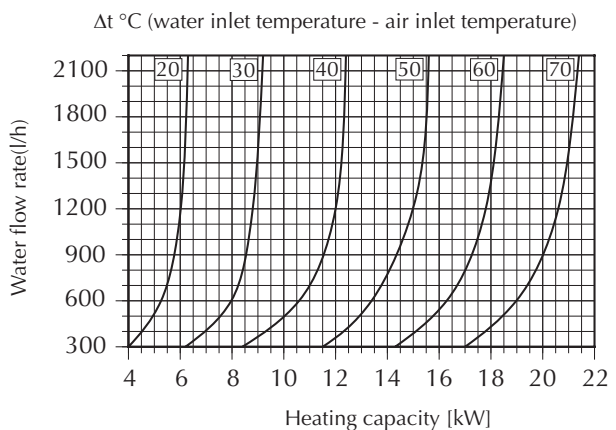

HEATING CAPACITY CORRECTION FACTORS

The heat yields refer to the maximum speed. For the rest of the speeds the values must be multiplied by the following factors:

MODEL	FHX 22	FHX 32	FHX 42	FHX 50	FHX 62	FHX 82
Medium speed	0.79	0.82	0.87	0.87	0.85	0.88
Minimum speed	0.56	0.68	0.69	0.63	0.64	0.71

HEATING CAPACITY YIELDED WITH A 4-ROW COIL (FHX_UMP - FHX_UVPO)

FHX 24

Δt °C (water inlet temperature - air inlet temperature)

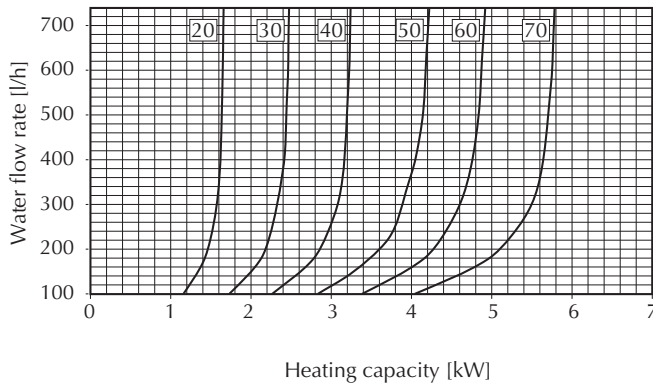

FHX 34

Δt °C (water inlet temperature - air inlet temperature)

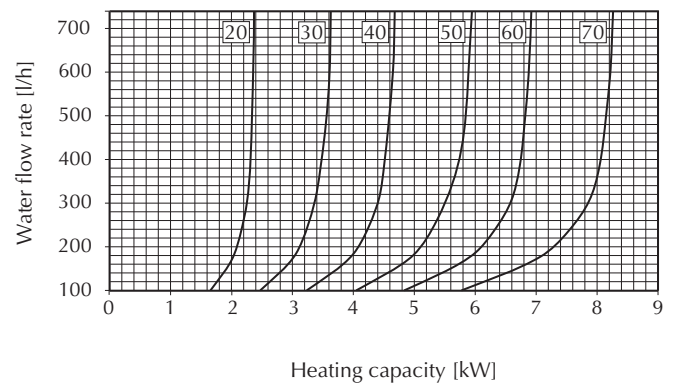

FHX 44

Δt °C (water inlet temperature - air inlet temperature)

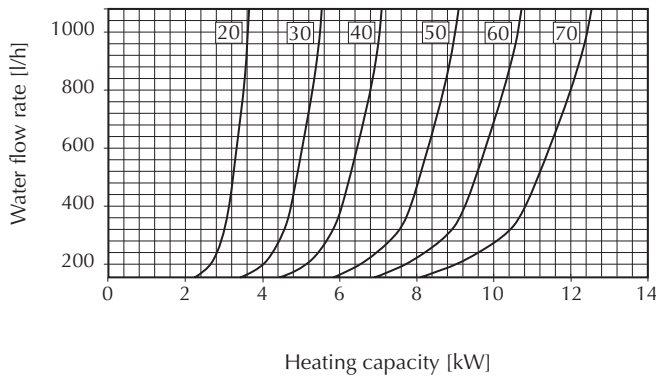

FHX 54

Δt °C (water inlet temperature - air inlet temperature)

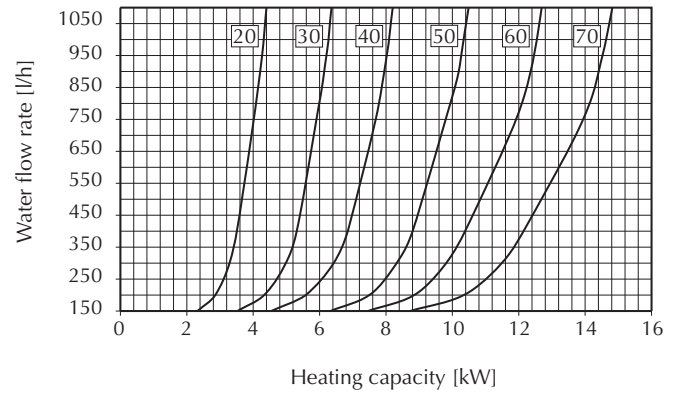

FHX 64

Δt °C (water inlet temperature - air inlet temperature)

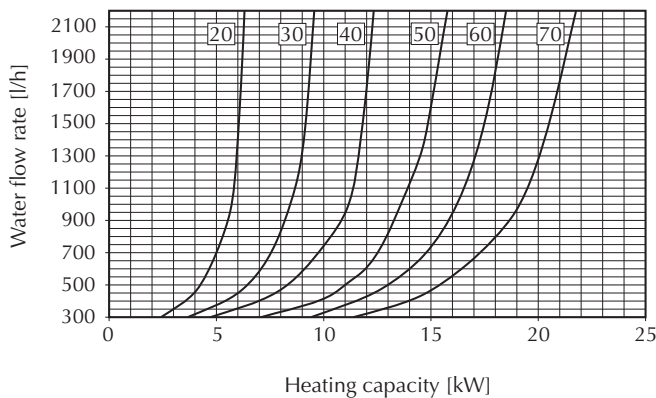

FHX 84

Δt °C (water inlet temperature - air inlet temperature)

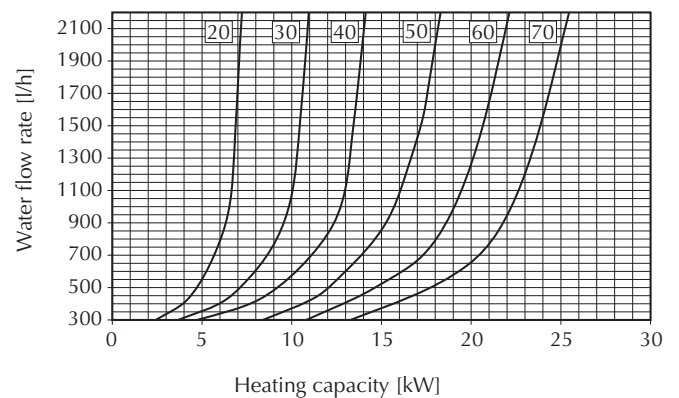

HEATING CAPACITY CORRECTION FACTORS

The heat yields refer to the maximum speed. For the rest of the speeds the values must be multiplied by the following factors:

MODEL	FHX 24	FHX 34	FHX 44	FHX 54	FHX 64	FHX 84
Medium speed	0.81	0.83	0.81	0.87	0.80	0.84
Minimum speed	0.56	0.66	0.60	0.62	0.59	0.65

DISCHARGE HEAD IN WALL/CEILING-MOUNTING VERSIONS

The fan coils in the PO series have been designed to make it possible to adjust the head supplied by the fan upon pressure drops in the duct by choosing an appropriate set of three speeds.

The tables show the useful head of the machines with a boost-

ed multi-speed motor on the basis of the air flow rate and fan speed (L1...L7).

The same diagrams show the curves relating to the models with a standard motor (P-PE) at maximum and medium speeds.

L1: max. speed version PO

L7: min. speed version PO

----- max. speed version P

----- min. speed version P

English

FHX 22 - 24

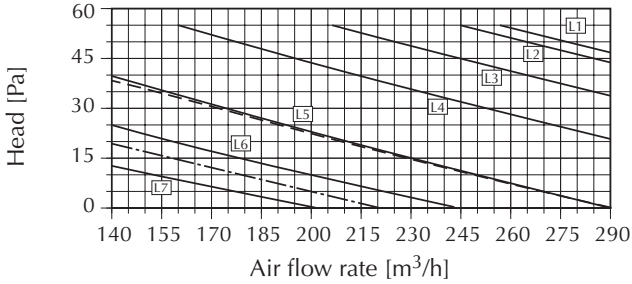

FHX 32 - 34

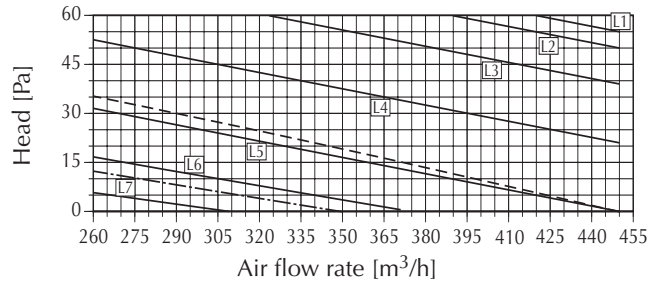

FHX 42 - 44

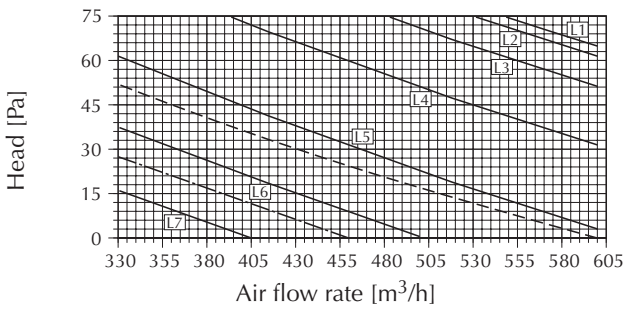

FHX 50 - 54

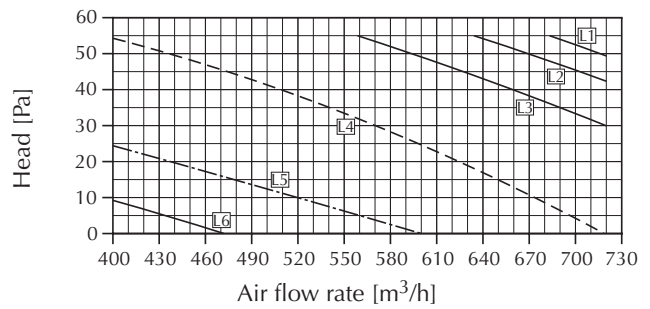

FHX 62 - 64

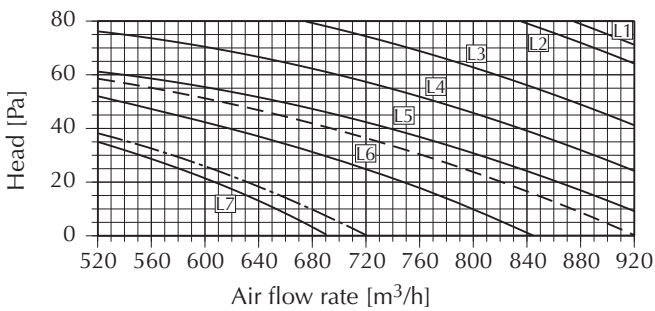

FHX 82 - 84

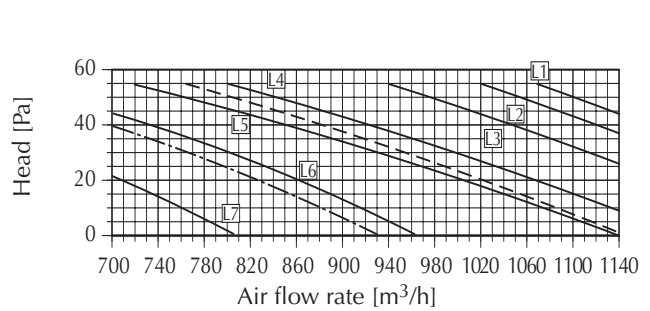

3R COIL PRESSURE DROPS

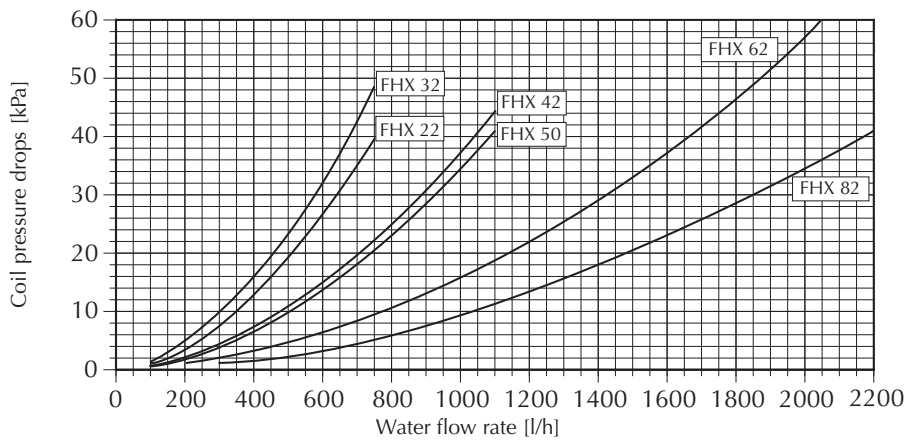

The pressure drops in the previous diagram refer to a medium water temperature of 10 °C. The following table shows the correction to apply to the pressure drops when the medium water temperature varies.

Water medium temperature °C	5	10	15	20	50	60	70
Multiplication coefficient	1.03	1	0.96	0.91	0.78	0.75	0.72

4R COIL PRESSURE DROPS

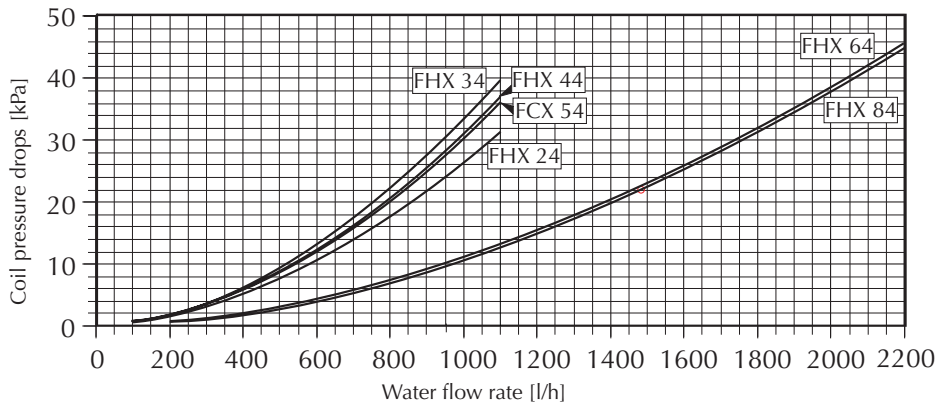



The pressure drops in the previous diagram refer to a medium water temperature of 10 °C. The following table shows the correction to apply to the pressure drop when the medium water temperature varies.

Water medium temperature °C	5	10	15	20	50	60	70
Multiplication coefficient	1.03	1	0.96	0.91	0.78	0.75	0.72

CORRECTION FACTORS WHEN OPERATING USING GLYCOL WATER

Key:

-  Pressure drop
-  Air flow rate
-  Yield

COOLING FUNCTION MODE

HEATING FUNCTION MODE

GLYCOL WATER AT 10%

English

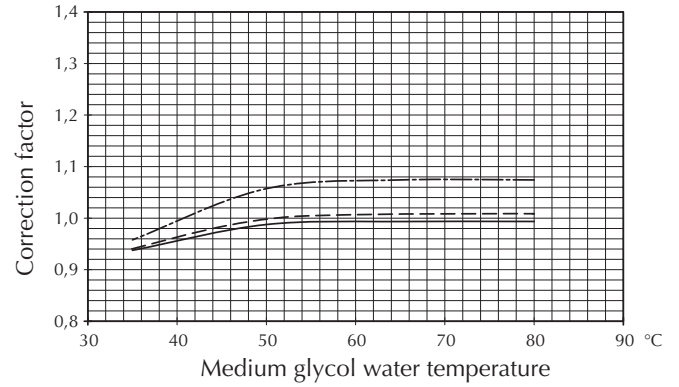
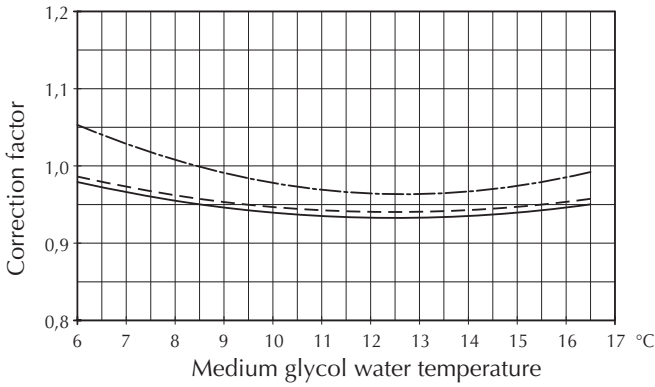

GLYCOL WATER AT 20%

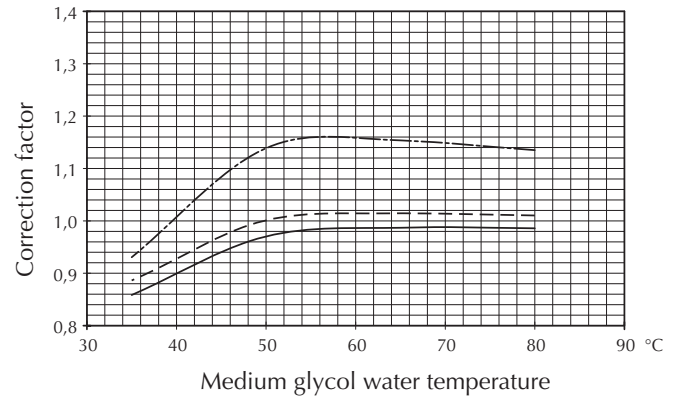
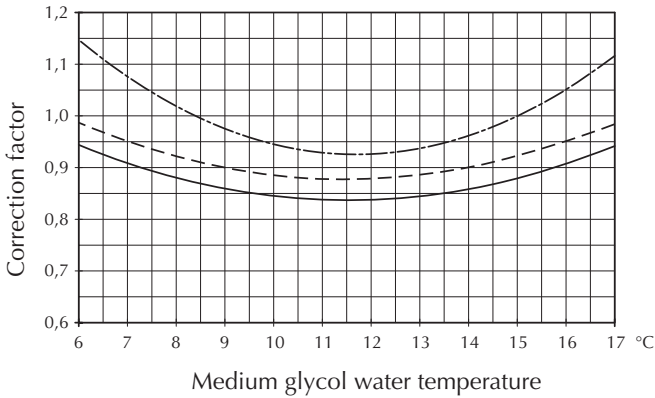

GLYCOL WATER AT 35%

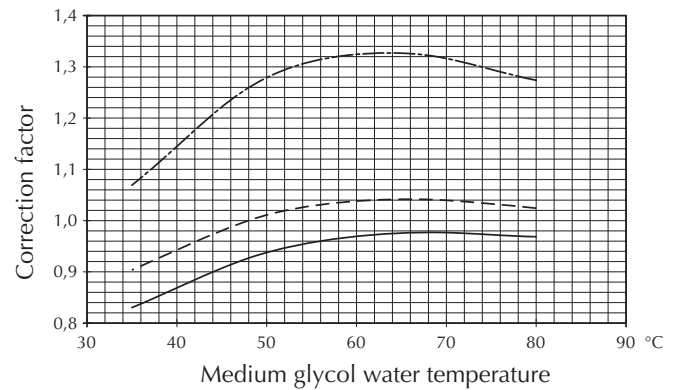
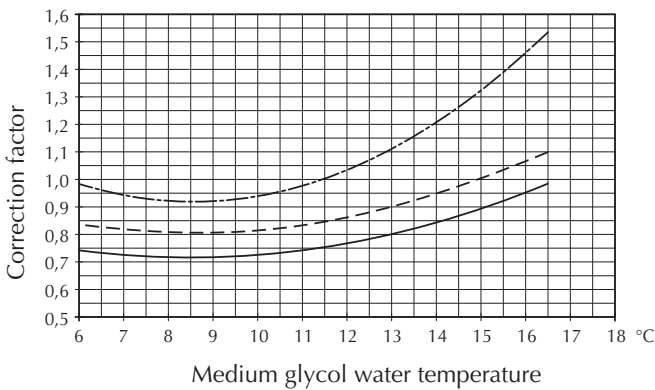

SOUND POWER LEVEL expressed in dB

Model	Speed	Central band frequency [Hz]							Overall	
		125	250	500	1000	2000	4000	8000	dB	dB (A)
FHX22	Max.	45.6	50.6	48.4	44.7	41.3	33.3	19.7	54.2	50 (E)
	Medium	39.2	44.9	41.7	37.6	31.9	25.8	7.5	47.9	43 (E)
	Min.	25.8	33.0	29.1	26.2	19.9	16.2	2.6	35.7	31 (E)
FHX32	Max.	43.6	48.8	46.4	42.7	39.0	31.3	17.7	52.3	48 (E)
	Med.	37,0	43,0	39,7	35,7	29,9	24,0	5,4	45,9	41 (E)
	Min.	28.9	36.1	32.2	29.0	22.9	19.2	3.1	38.8	34 (E)
FHX42	Max.	46.6	51.8	49.4	45.7	42.0	34.3	20.7	55.3	51 (E)
	Med.	39.6	44.8	42.4	38.7	35.0	27.3	13.7	48.3	44 (E)
	Min.	31.9	39.1	35.2	32.0	25.9	22.2	6.1	41.8	37 (E)
FHX50	Max.	51.6	56.8	54.4	50.7	47.0	39.3	25.7	60.3	56 (E)
	Med.	46.6	51.8	49.4	45.7	42.0	34.3	20.7	55.3	51 (E)
	Min.	37.6	42.8	40.4	36.7	33.0	25.3	11.7	46.3	42 (E)
FHX62	Max.	52.6	57.5	55.4	51.7	48.3	40.3	26.7	61.2	57 (E)
	Med.	46.4	51.8	49.6	45.7	41.9	34.3	20.8	55.3	51 (E)
	Min.	37.7	42.6	40.4	36.8	33.0	25.3	11.7	46.3	42 (E)
FHX82	Max.	57.6	62.8	60.5	56.7	53.2	45.0	31.8	66.3	62 (E)
	Med.	52.4	57.8	55.5	51.7	48.2	40.1	26.7	61.3	57 (E)
	Min.	45.6	51.0	48.4	44.6	41.1	33.2	19.8	54.4	50 (E)

(E) =  Eurovent certified performances.

English

SOUND PRESSURE LEVEL expressed in dB (A)

Speed	Model FHX	22	32	42	50	62	82
Max.		41.5	39.5	42.5	47.5	48.5	53.5
Med.		34.5	32.5	35.5	42.5	42.5	48.5
Min.		22.5	25.5	28.5	33.5	33.5	41.5

Level of sound pressure (A-weighted) measured in the room with volume $V = 85 \text{ m}^3$; reverberation time $t = 0.5 \text{ s}$; direction factor $Q = 2$; distance $r = 2.5 \text{ m}$.

SOUND POWER LEVEL expressed in dB

Model	Speed	Central band frequency [Hz]							Overall	
		125	250	500	1000	2000	4000	8000	dB	dB (A)
FHX24	Max	46.5	51.6	49.3	45.7	42.3	34.3	20.8	54.2	51
	Med.	42,0	47,9	44,8	40,6	34,8	28,8	10,5	47,9	46
	Min.	29.8	37.2	33.1	30.0	23.8	20.2	5.1	35.7	35
FHX34	Max	43.7	48.8	46.5	42.7	39.1	31.3	17.6	52.3	48
	Med.	37,2	42,5	40,0	35,7	29,9	24,2	6,1	45,9	41
	Min.	30.8	38.0	34.2	31.1	24.9	21.2	5.7	38.8	36
FHX44	Max	50.4	55.8	53.7	49.3	46.0	38.5	24.7	55.3	55
	Med.	45,9	50,6	48,4	44,6	41,3	33,3	20,0	48,3	50
	Min.	36.2	42.5	39.4	36.2	29.8	26.2	9.9	41.8	41
FHX54	Max	51.8	56.8	54.2	50.7	47.3	39.2	25.5	60.3	56
	Med.	48,5	53,8	51,2	47,7	44,3	36,4	22,8	55,3	53
	Min.	40.0	44.8	42.3	38.7	35.2	27.3	13.9	46.3	44
FHX64	Max	52.3	57.6	55.4	51.7	48.3	41.1	26.5	61.2	57
	Med.	46,5	52,0	49,6	45,7	41,7	34,3	20,6	55,3	51
	Min.	39.6	44.5	42.4	39.1	34.8	27.9	13.7	46.3	44
FHX84	Max.	56.8	61.8	59.4	55.7	52.0	44.3	30.9	66.3	61
	Med.	52,5	57,7	55,5	51,7	48,2	40,3	26,6	61,3	57
	Min.	46.7	52.3	49.6	45.2	42.1	34.5	21.2	54.4	51

SOUND PRESSURE LEVEL expressed in dB (A)

Speed	Model FHX	24	34	44	54	64	84
Max.		42.5	39.5	46.5	47.5	48.5	52.5
Medium		37.5	32.5	41.5	44.5	42.5	48.5
Min.		26.5	27.5	32.5	35.5	35.5	42.5

Level of sound pressure (A-weighted) measured in the room with volume $V = 85 \text{ m}^3$; reverberation time $t = 0.5 \text{ s}$; direction factor $Q = 2$; distance $r = 2.5 \text{ m}$.

SOUND POWER LEVEL FOR DUCTED WALL/CEILING-MOUNTING FHX-PO MODELS expressed in dB

The level of the sound power emitted by the fan coils (FHX-PO) installed in ducts depends not only on the fan speed, but also the functioning point that is determined compatibly with the duct pressure drop.

The following diagrams make it possible to determine the level of the sound power (A-weighted), expressed in dB (A) and shown at the relative curve on the basis of the flow rate and head values.

The overall levels of the sound power, expressed in dB (A), are shown at each curve

FHX 22

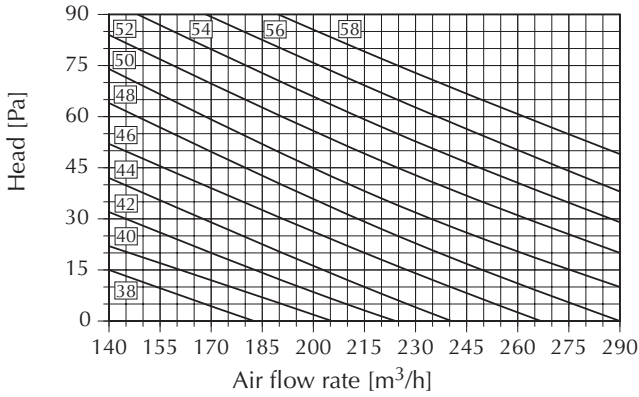

FHX 32

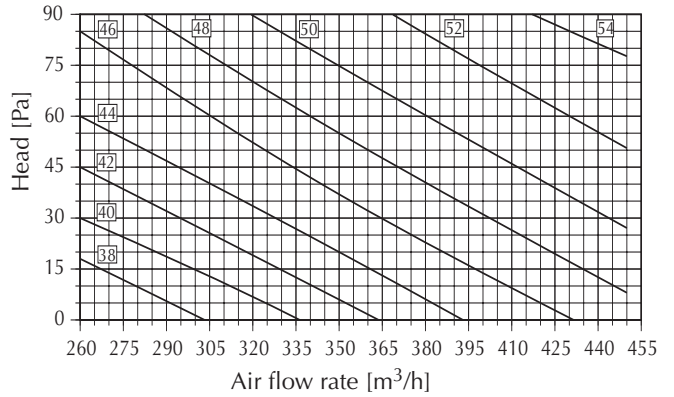

FHX 42

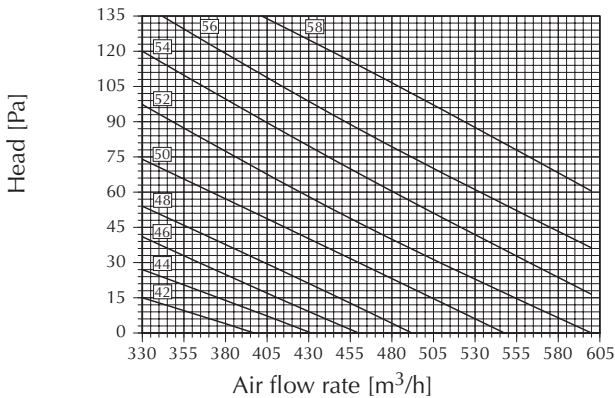

FHX 50

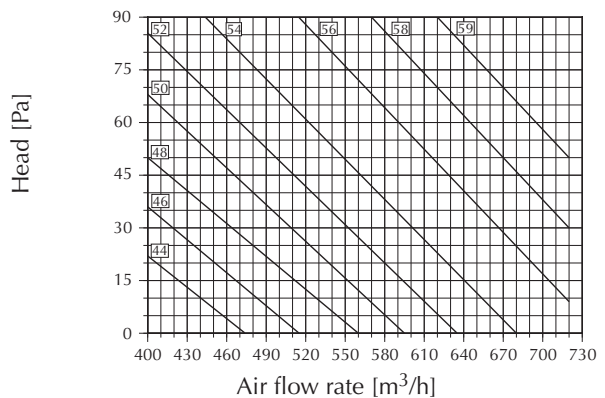

FHX 62

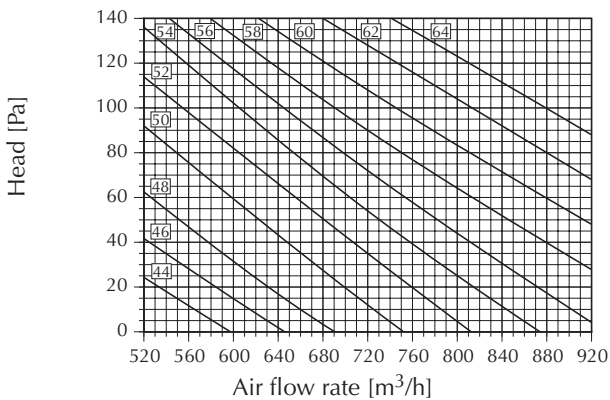

FHX 82

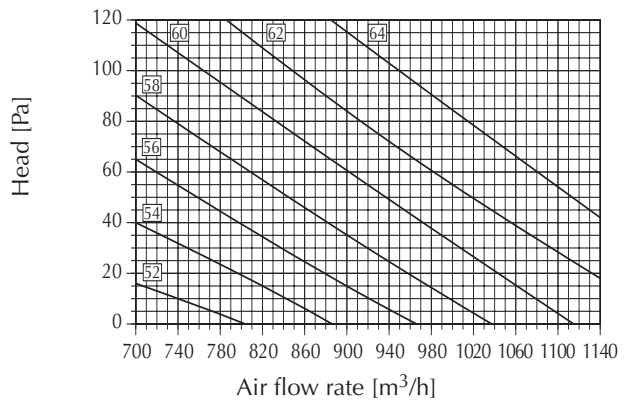

English

BC AUXILIARY TRAY FOR COLLECTING CONDENSATE

Made of thermoplastic material, it collects and channels outwards the condensate that is formed during the summer functioning mode, near the non-insulated plumbing connections. In particular, the **BC4** tray is used on all the sizes with vertical installation.

Warning: The VCF valve and the BC4 tray cannot be installed at the same time on the same fan coil.

Warning: BC8 and BC9 cannot be applied to fan coils with a protective cabinet.

The **BC5** tray is installed on FHX 22, 32, 42, 50 and 24, 34, 44, 54 with horizontal installation.

The **BC6** tray is installed on FHX 62, 82 and 64, 84 with horizontal installation.

The **BC8** tray is installed on FHX 22, 32, 42, 50 and 24, 34, 44, 54 for UVP - UVPO model with horizontal installation.

The **BC8** tray is installed on FHX 62, 82 and 64, 84 for UVP - UVPO models with horizontal installation.

GA INTAKE LOUVER

In sheet metal with fixed fins, polyurethane powder-coated. The frame structure is supplied as an accessory.

GAF INTAKE LOUVER WITH FRAME AND FILTER

In sheet metal with fixed fins, polyurethane powder-coated, complete with frame for the insertion of the filter. The frame structure and filter are supplied as accessories.

GM DELIVERY LOUVER

In sheet metal varnished with high resistance enamel; complete with orientable louvers in thermoplastic material for air diffusion. The frame structure is supplied as an accessory.

PA INTAKE PLENUM

Made of galvanised sheet metal, complete with delivery couplings for Ø 200 mm circular section ducts. This plenum is suitable for two mounting positions- the intake axially positioned with regards to the fan coil or with intake at 90° .

PA F FRONT INTAKE PLENUM

Made of galvanised sheet metal, complete with delivery couplings for Ø 200 mm circular section ducts. The plenum is suitable to have a front intake coupling parallel to the fan coil delivery and for sizes PA 32F - 42F - 62F also with lateral intake.

PC REAR CLOSING PANEL

Allows you to close the rear part of the fan coil if it is visible. Its application is necessary for installation at a distance from the wall, to prevent access to the control board (in compliance with the current regulations).

PM DELIVERY PLENUM

In galvanised sheet metal, externally insulated, complete with delivery couplings in plastic for circular section ducts.

RD STRAIGHT COUPLING FOR AIR DELIVERY

Made of galvanised sheet metal, it is used to channel the air when the fan coil is vertically or horizontally flush-mounted.

RDA STRAIGHT COUPLING FOR AIR INTAKE

Made of galvanised sheet metal, it is used to channel the intake air when the unit is vertically or horizontally flush-mounted.

RP 90° COUPLING FOR AIR DELIVERY

In galvanised sheet metal, it is used to channel the air when the fan coil is vertically or horizontally flush-mounted.

RPA 90° COUPLING FOR AIR INTAKE

Made of galvanised sheet metal, it is used to channel the intake air when the unit is vertically or horizontally flush-mounted.

SE EXTERNAL AIR DAMPER

The UVP and UVPO models with feet are equipped with this damper that enables changing the air in the rooms. It is installed at the fan coil base, in between the feet. The manual control is located at the right foot.

SIT 3

Each fan coil fitted with an SIT3 card becomes a Slave and can be controlled from a centralised control panel with electromechanical selector or with an SIT 5. Up to ten fan coils fitted with SIT 3s can be applied to a single centralised control. **The electronically-driven control panels must also interface with an SIT 5.**

SIT 5

The accessory SIT 5, a Master interface card, is connected to the electronic control panels that control valves and germicidal lamps. The SIT5 interface card requires that all fan coils connected to it (up to 10) be fitted with SIT3 Slave interface cards.

SW3 MINIMUM WATER TEMPERATURE SENSOR

The SW3 accessory is a sensor that detects the temperature of the water inside the heating coil and it prevent the fans from working when the water temperature is less than 39 °C. The SW3 sensors are fit for 230V single phase power supply. The sensor has a 2500 mm long cable.

VCF 3-WAY VALVES KIT

The SW3 sensor should be used with this accessory.

Kits complete with copper pipe fittings and 3-way valves of the "all or nothing" type that work with a 230 V ~ 50Hz power supply.

Available for fan coils:

- with a 3- or 4-row coil (VCF41, VCF42, VCF43),

- with a 4-row coil (VCF42, VCF43),

*** Warning: The VCF valve and the BC4 tray cannot be installed at the same time on the same fan coil.**

ZX7 - ZX8 FEET FOR WALL/CEILING-MOUNTING MODEL

In galvanised sheet metal, they are assembled at the base of the fan coil when it rested on the floor and is then flush-mounted on the wall.

CONTROL PANELS

PXA E CONTROL PANEL WITH MULTIFUNCTION ELECTRONIC THERMOSTAT

Multifunction electronic room thermostat for fan coils. Simplified controls with only two selectors to control temperature and ventilation, 3 speeds + automatic speed, on-off and automatic summer-winter switching, according to water temperature. The minimum water temperature sensor SW is available as an accessory. It interrupts the heating function when the water temperature is below 35°C. Wall-mounted installation. See the accessory instructions for further information.

PXA I CONTROL PANEL WITH MULTIFUNCTION ELECTRONIC THERMOSTAT

Multifunction electronic room thermostat for fan coils. Simplified controls with only two selectors to control temperature and ventilation, 3 speeds + automatic speed, on-off and automatic summer-winter switching, according to water temperature. Equipped with a minimum water temperature sensor that interrupts the heating function when the water temperature is below 35°C. Installation on machine.

See the accessory instructions for further information.

ACCESSORIES

Consult the compatibility table to make your choice.

Accessory	FHX fan coil						Model
	Size						
	22 - 24	32 - 34	42 - 44	50 - 54	62 - 64	82 - 84	
BC	4	✓	✓	✓	✓	✓	all
	5	✓	✓	✓	✓		all
	6					✓	all
	8 (*)	✓	✓	✓	✓		UVP-UVPO
	9 (*)					✓	UVP-UVPO
GA	22	✓					UVP-UVPO
	32		✓				UVP-UVPO
	42			✓	✓		UVP-UVPO
	62					✓	UVP-UVPO
	62	✓				✓	UVP-UVPO
GAF	22	✓					UVP-UVPO
	32		✓				UVP-UVPO
	42			✓	✓		UVP-UVPO
	62					✓	UVP-UVPO
GM	22	✓					UVP-UVPO
	32		✓				UVP-UVPO
	42			✓	✓		UVP-UVPO
	62					✓	UVP-UVPO
PA	22	✓					UVP-UVPO
	32		✓				UVP-UVPO
	42			✓	✓		UVP-UVPO
	62					✓	UVP-UVPO
PA F	22	✓					UVP-UVPO
	32		✓				UVP-UVPO
	42			✓	✓		UVP-UVPO
	62					✓	UVP-UVPO
PC	23	✓					UV
	33		✓				UV
	43			✓	✓		UV
	62					✓	UV
PM	22	✓					UVP-UVPO
	32		✓				UVP-UVPO
	42			✓	✓		UVP-UVPO
	62					✓	UVP-UVPO
RD	22	✓					UVP-UVPO
	32		✓				UVP-UVPO
	42			✓	✓		UVP-UVPO
	62					✓	UVP-UVPO
RDA	22	✓					UVP-UVPO
	32		✓				UVP-UVPO
	42			✓	✓		UVP-UVPO
	62					✓	UVP-UVPO
RP	22	✓					UVP-UVPO
	32		✓				UVP-UVPO
	42			✓	✓		UVP-UVPO
	62					✓	UVP-UVPO
RPA	22	✓					UVP-UVPO
	32		✓				UVP-UVPO
	42			✓	✓		UVP-UVPO
	62					✓	UVP-UVPO
SE	20X (**)	✓					UVP-UVPO
	30X (**)		✓				UVP-UVPO
	40X (**)			✓	✓		UVP-UVPO
	80X (**)					✓	UVP-UVPO
SIT3	✓	✓	✓	✓	✓	✓	all
SIT5	✓	✓	✓	✓	✓	✓	all
SW3	✓	✓	✓	✓	✓	✓	all
VCF	41 (***)	✓	✓				all
	42 (***)			✓	✓		all
	43 (***)					✓	all
ZX	7	✓	✓	✓	✓		UVP-UVPO
	8					✓	UVP-UVPO

English

The 4-row coil models are available only in the UVP and UVPO versions.
(*) BC8 and BC9 cannot be applied to fan coils with a protective cabinet.

(**) The SE accessories have to be installed in combination with ZX feet.
(***) The 4-row coil models can be combined only with VCF42 (FHX 24-34-44-54) and VCF43 (FHX 64-84) valves.

ACCESSORIES

PANELS / FAN COILS COUPLING

Models	IN	OUT	FHX - UV	FHX - UVP	FHX - UVPO
PXAE		✓	✓	✓	✓
PXAI	✓		✓		

IN = control panel installed on the machine

OUT = wall-mounted control panel

English

CONTROL PANELS WITH THERMOSTAT

PXAE - PXAI

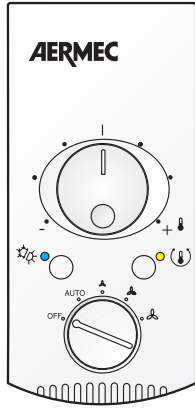

SW3 MINIMUM WATER TEMPERATURE SENSOR

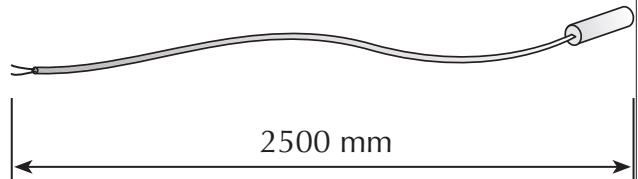

SIT3 - SIT5 INTERFACE CARDS

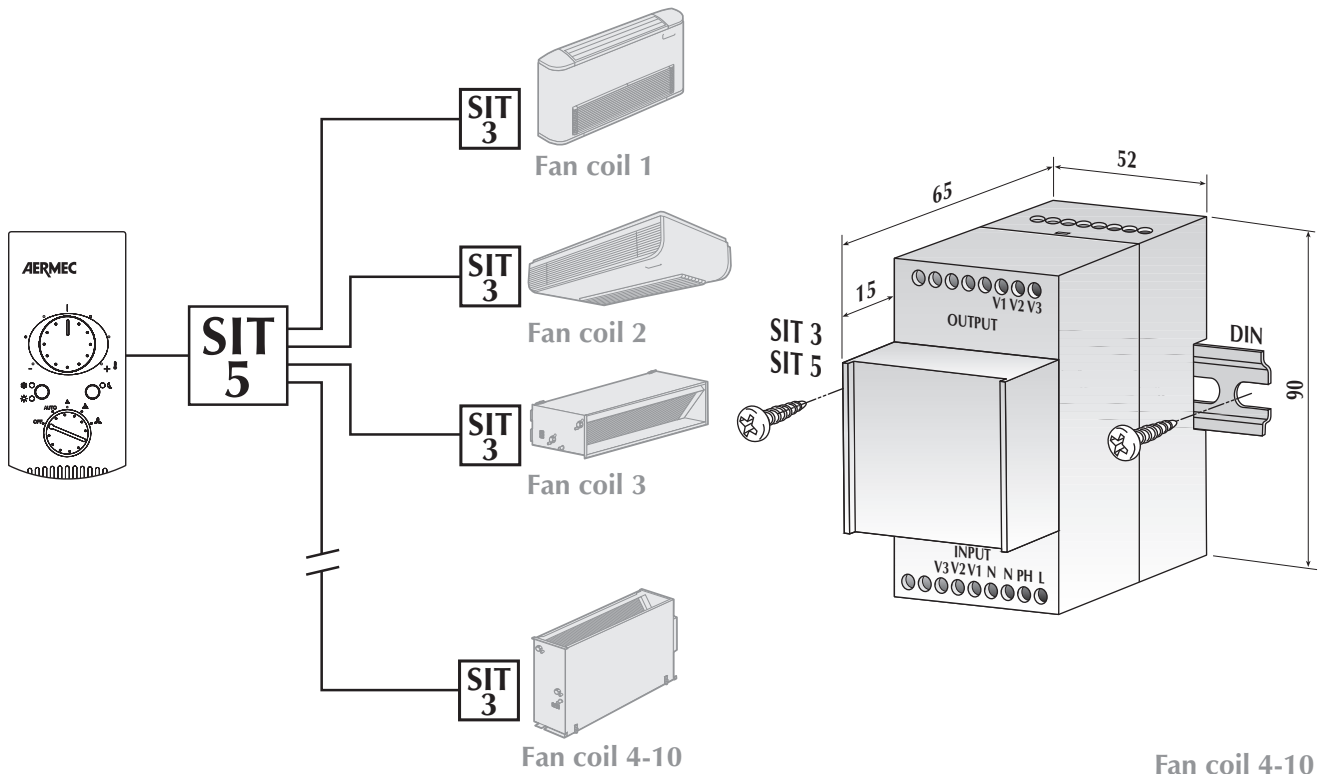

Fan coils

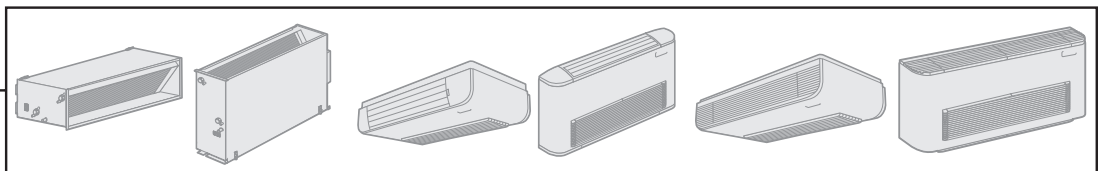

BC4 CONDENSATE COLLECTION TRAY

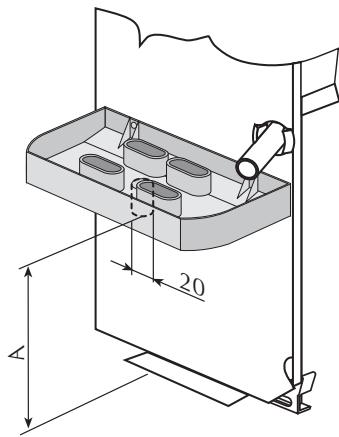

The VCF valve and the BC4 tray cannot be installed at the same time on the same fan coil.

DIMENSIONS [mm]

Models	FHX 22-50	FHX 62-82
A [mm]	109	126

BC5-6 CONDENSATE COLLECTION TRAY

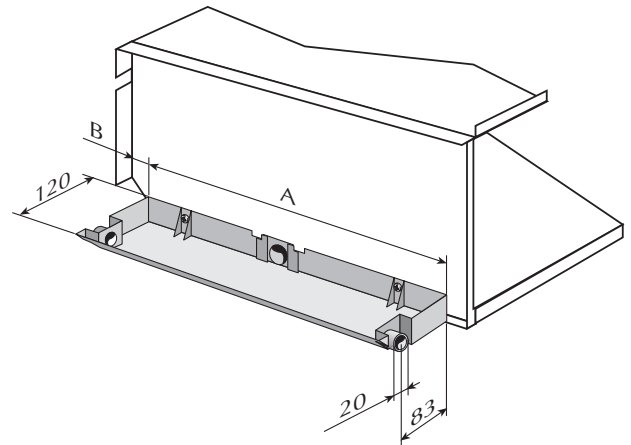

DIMENSIONS [mm]

Models	BC 5	BC 6
A [mm]	375	476
B [mm]	69	72

BC8-9 CONDENSATE COLLECTION TRAY TO BE HORIZONTALLY MOUNTED

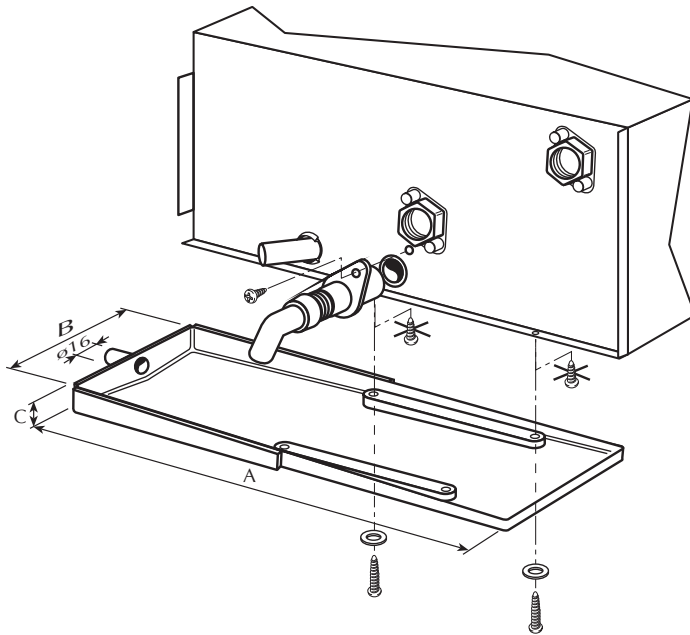

DIMENSIONS [mm]

Models	BC 8	BC 9
A [mm]	420	524
B [mm]	146	146
C [mm]	25	25

ACCESSORIES

English

GA INTAKE LOUVER

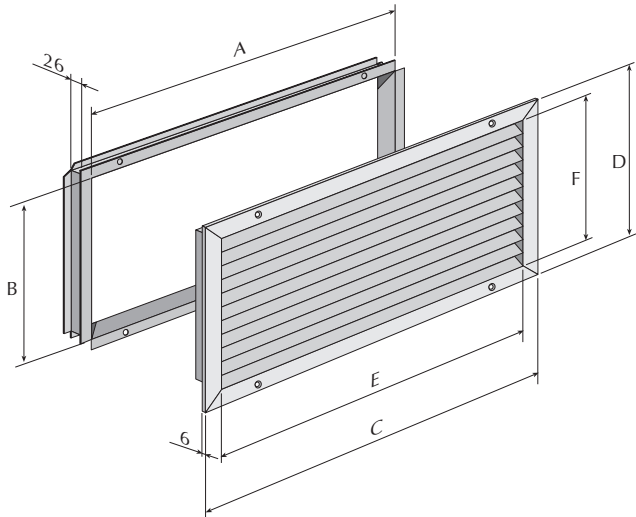

DIMENSIONS [mm]

Models	A	B	C	D	E	F
GA 22	506	214	550	258	500	208
GA 32	737	214	781	258	731	208
GA 42	957	214	1001	258	951	208
GA 62	1078	244	1122	288	1072	238

GAF INTAKE LOUVER

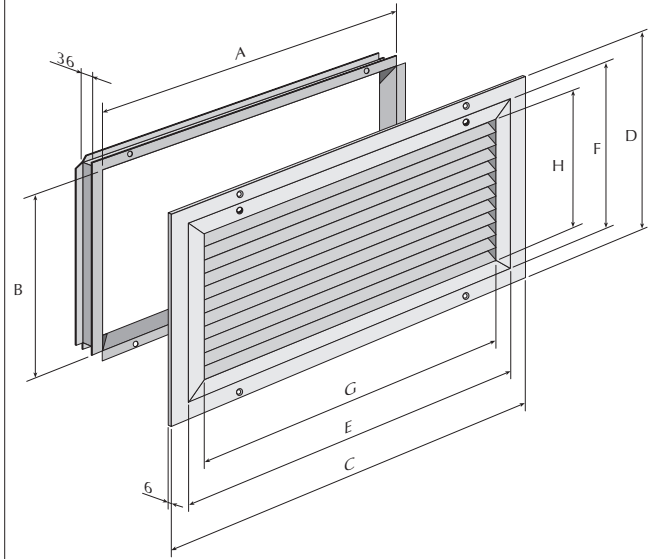

DIMENSIONS [mm]

Models	A	B	C	D	E	F	G	H
GAF 22	561	270	605	314	554	262	500	208
GAF 32	792	270	836	314	785	262	731	208
GAF 42	1012	270	1056	314	1005	262	951	208
GAF 62	1133	300	1177	344	1126	292	1072	238

GM DELIVERY LOUVER

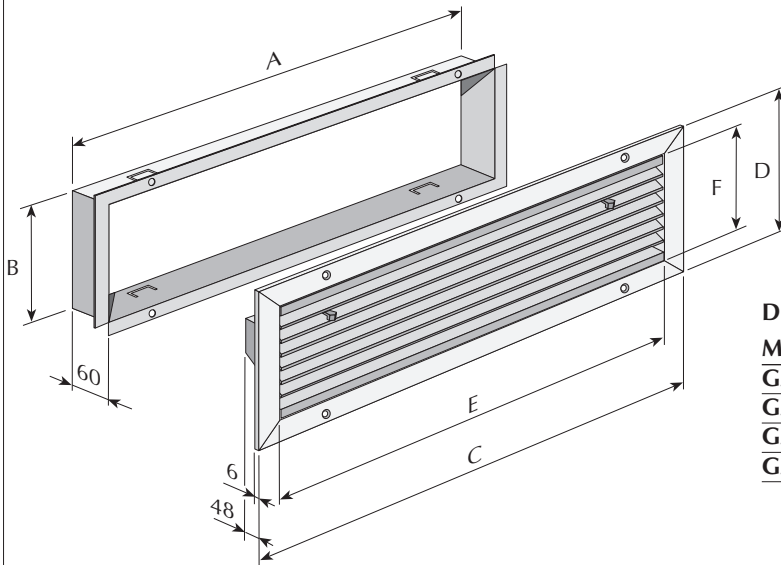

DIMENSIONS [mm]

Models	A	B	C	D	E	F
GA 22	457	134	502	178	452	128
GA 32	688	134	733	178	683	128
GA 42	908	134	953	178	903	128
GA 62	1029	134	1074	178	1024	128

PC REAR CLOSING PANEL

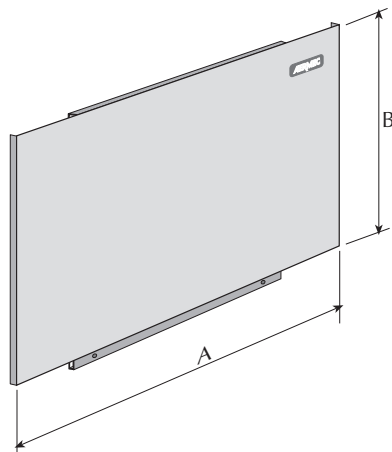

DIMENSIONS [mm]

Models	PC 22	PC 32	PC42	PC62
A [mm]	740	971	1191	1312
B [mm]	437	437	437	542

PA INTAKE PLENUM

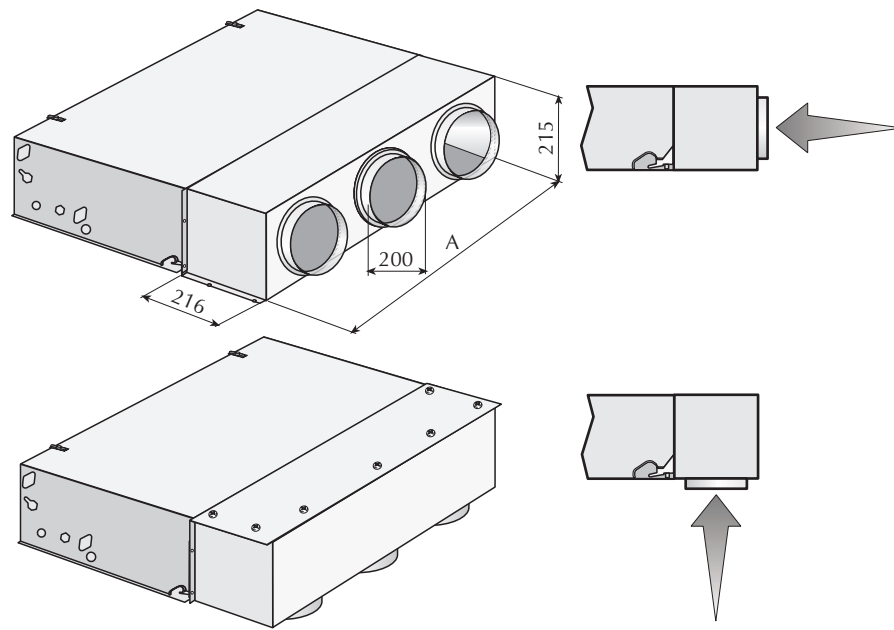

Models	PA 22	PA 32	PA 42	PA 62
A [mm]	500	731	951	1072
Number of inlet vents	2	2	3	4

PA-F FRONT INTAKE PLENUM

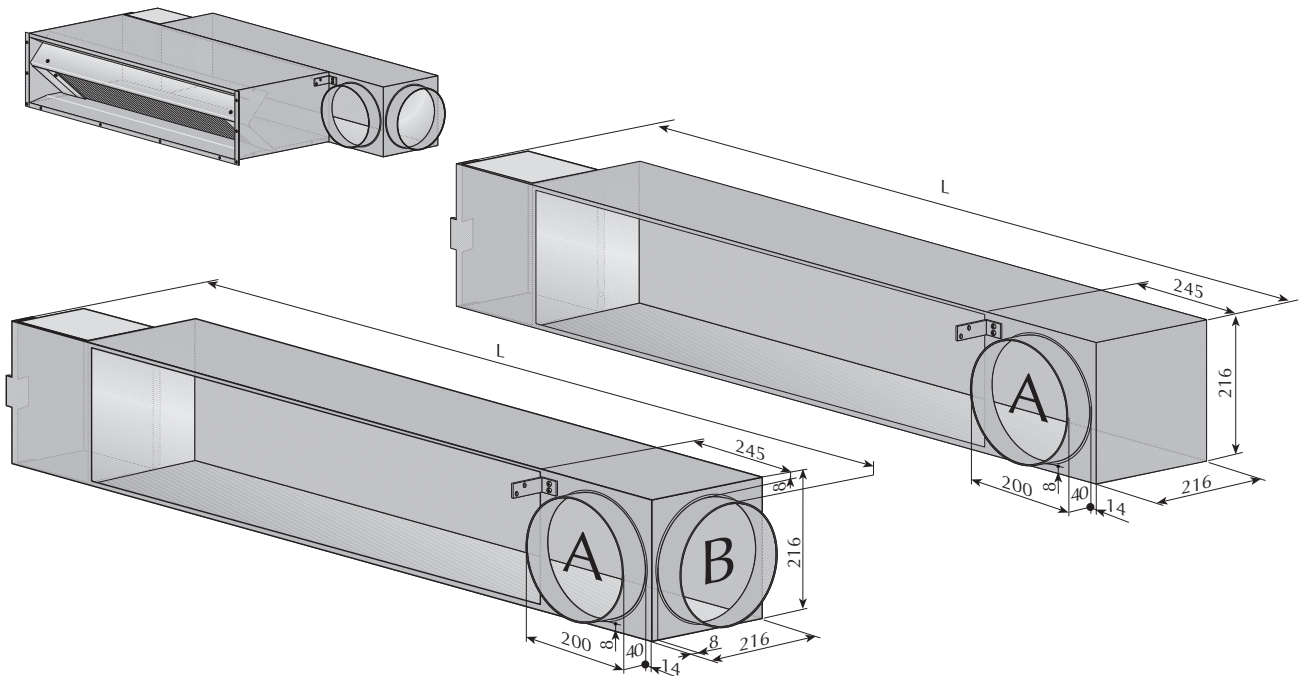

Models	PA 22 F	PA 32 F	PA 42 F	PA 62 F
L [mm]	768	1039	1259	1381
Number of intake vents	1 (A)	2 (A+B*)	2 (A+B*)	2 (A+B)

B* = Closed inlet vent, to use it remove the push-out closing component, in the PA 42F plenum combined with the FHX 50/54 P - PO models, it is mandatory to remove the push-out and use the two intake vents.

PM DELIVERY PLENUM

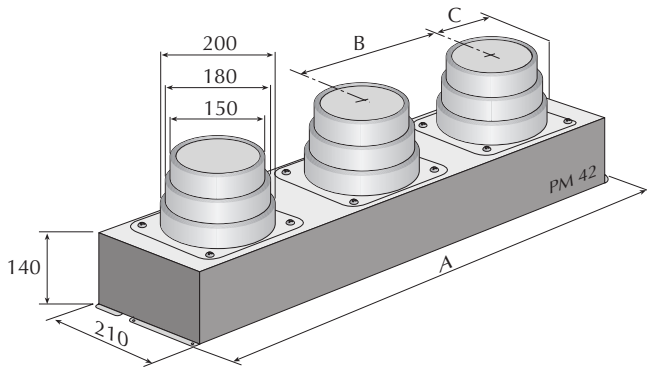

DIMENSIONS [mm]

Models	PM 22	PM 32	PM 42	PM 62
A [mm]	522	753	973	1094
B [mm]	250	370	320	270
C [mm]	136	191	166	142
No. of delivery outlet blocks	2	2	3	4

English

RDA STRAIGHT INTAKE COUPLING

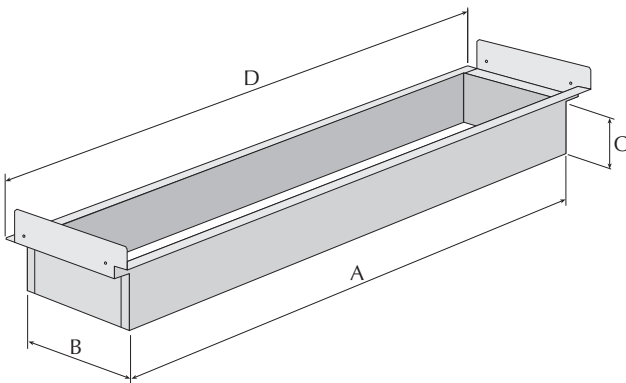

DIMENSIONS [mm]

Models	A	B	C	D
RDA 22	455	180	60	499
RDA 32	686	180	60	730
RDA 42	906	180	60	950
RDA 62	1027	180	60	1071

RPA INTAKE COUPLING - 90°

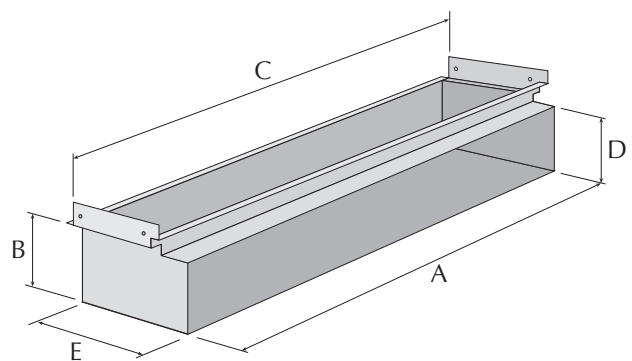

DIMENSIONS [mm]

Models	A	B	C	D	E
RPA 22	455	150	499	132	226
RPA 32	686	150	730	132	226
RPA 42	906	150	950	132	226
RPA 62	1027	150	1071	132	226

RD STRAIGHT DELIVERY COUPLING

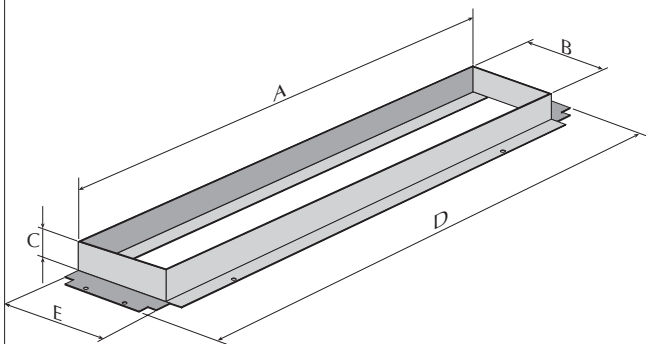

DIMENSIONS [mm]

Models	A	B	C	D	E
RD 22	455	132	60	522	149
RD 32	686	132	60	753	149
RD 42	906	132	60	973	149
RD 62	1027	132	60	1094	149

RP DELIVERY COUPLING - 90°

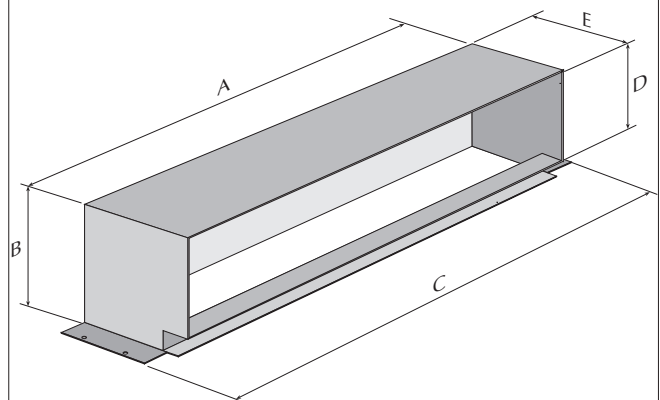

DIMENSIONS [mm]

Models	A	B	C	D	E
RP 22	455	156	522	132	161
RP 32	686	156	753	132	161
RP 42	906	156	973	132	161
RP 62	1027	156	1094	132	161

SE EXTERNAL AIR DAMPER

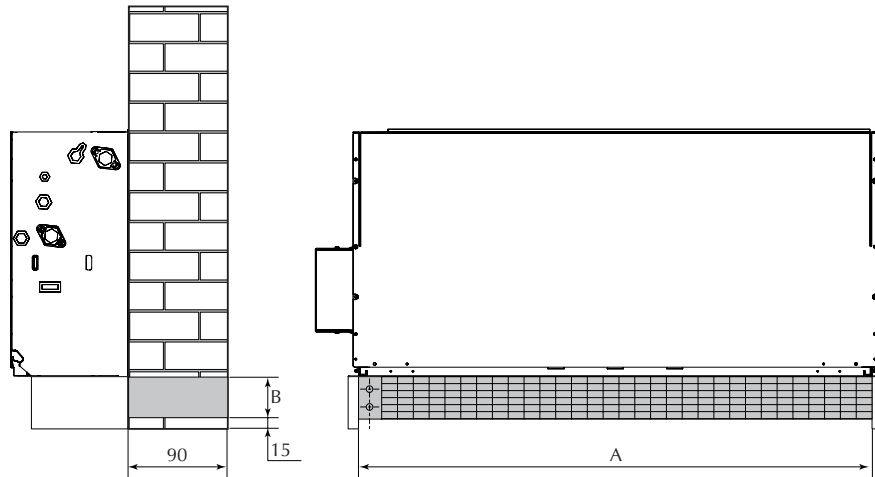

DIMENSIONS [mm]

Models	SE 20 X	SE 30 X	SE 40 X	SE 80 X
A	546	777	997	1118
B	65	65	65	85

TREATED EXTERNAL AIR

Models		FHX 22	FHX 32	FHX 42	FHX 50	FHX 62	FHX 82	
Air flow rate	max.	[m ³ /h]	60	80	100	140	180	220
	med.	[m ³ /h]	50	70	80	115	160	190
	min.	[m ³ /h]	40	50	65	90	120	150

ZX 7-8 FEET FOR WALL/CEILING-MOUNTING MODEL

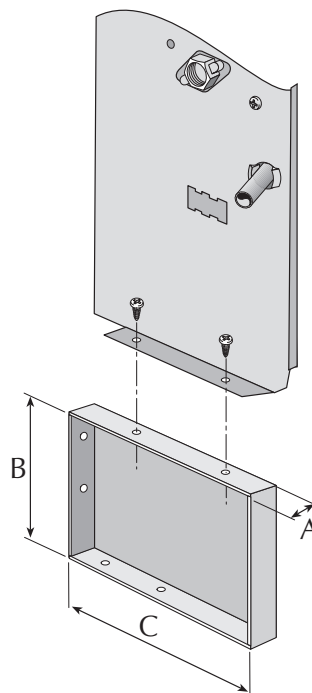

[mm]	A	B	C
ZX 7	20	88	199
ZX 8	20	108	199

TECHNICAL SPECIFICATIONS

Power supply: 230V (±10%) ~ 50Hz
 Initial input power: 46VA
 Input power during operation: 2.5W
 Water temperature range: 4°C - 80°C
 Usable liquids: water (with glycol ≤ 50%)
 Operating time: 2 min - 4 min
 Maximum differential pressure: 30kPa
 Maximum working pressure applied to fan coils: 800kPa

Environmental operating conditions
 temperature: 0°C - 40°C
 relative humidity: 10% - 90%
 without condensation

Environmental storage conditions
 temperature: -18°C - 60°C
 relative humidity: 10% - 90%
 without condensation

Actuator water protection level: IP44 in compliance with EN 60529
 Type II

Actuator electrical protection level:
 Flow direction in the valve (see figure)
 with valve fed A - AB
 with valve not fed B - AB

Valve connections [mm]

Models	VCF 41	VCF 42	VCF 43
A - AB - B	3/4"	3/4"	3/4"

Pressure drop

Models	VCF 41	VCF 42	VCF 43
Kvs AB-A	2.5	2.5	2.5
Kvs AB-B (by-pass)	1.6	1.6	1.6

$$\Delta p = \left(\frac{10 q}{Kvs} \right)^2 \Delta p \text{ [kPa]} = \text{Pressure drop}$$

$$q \text{ [m}^3\text{/h]} = \text{Water flow rate}$$

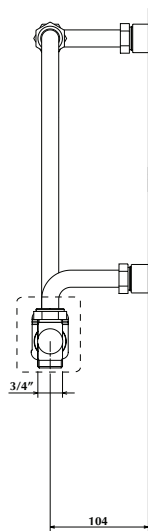
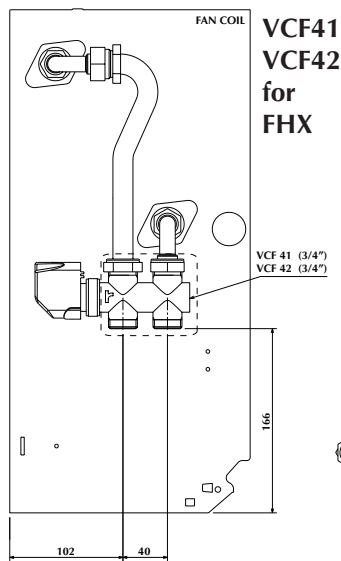
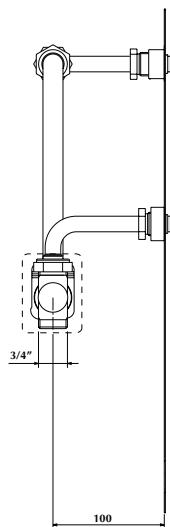
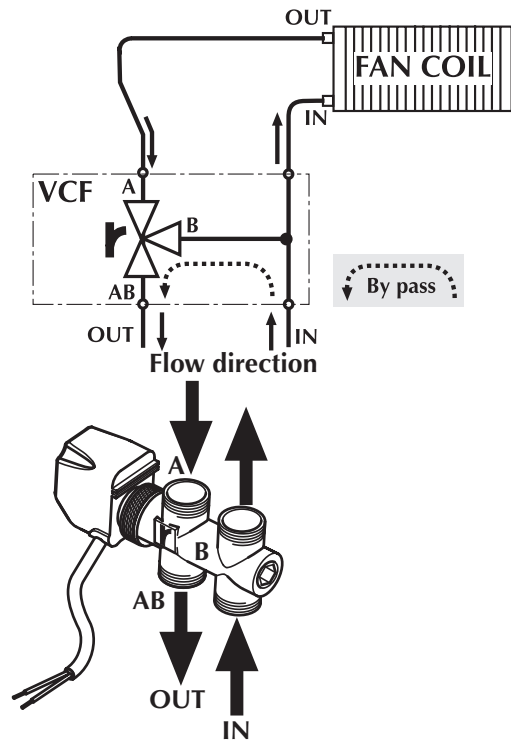

VCF43 for FHX

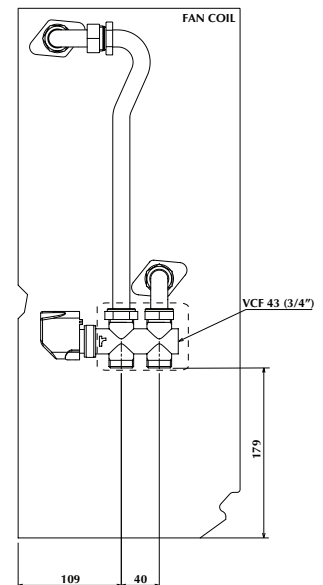
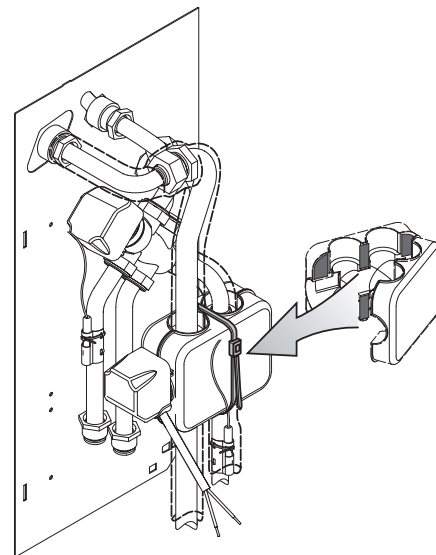

The VCF valve and the BC4 tray cannot be installed at the same time on the same fan coil.

INSTALLATION

WARNING! DANGER! Before performing any procedures, please consult the chapter entitled "Important information and maintenance" in this manual.

Instructions which are essential for the proper installation of the equipment are given here.

INSTALLING THE UNIT

To install the unit, proceed as follows:

- Before beginning the installation process, make sure that the technical areas (indicated in this manual) necessary for correct operation, maintenance and replacement of the germicidal lamps have been left free.

- Remove the housing by loosening the screws (FHX UV), or rather the front protective panel in the case of wall/ceiling-mounted versions (FHX UVP - FHX UVPO) with a size of between 22-24 and 50-54.

- Use wall expansion plugs (not supplied) for wall or ceiling-mounted installations.

- Perform the hydraulic connections.

The position and diameter of the water connections are shown in the dimensions.

You are advised to adequately insulate water lines, or fit the auxiliary condensate drain tray (available as an accessory), to prevent dripping during the cooling function.

In the case of horizontal installation, fit the condensate drain connection with $\varnothing 20.5$ mm supplied, in accordance with the illustration in the figure. Make sure you seal the connection between the drip tray and the fitting with silicone.

The condensate drain network must be properly scaled and the piping situated in such a way as to keep an adequate slope along the route (min. 1%). If condensate is discharged into the sewage system, install a siphon to prevent the return of unpleasant odours into the room.

- Make the electrical wirings as shown in the wiring diagrams.

- Record both the INSTALLATION DATE and the lamp code [EMITTER CODE] (also shown in the manual) on the label affixed to the unit. This will be useful when scheduling the yearly operations to replace the lamp.

- Replace the casing, or the front protective panel, without forgetting to connect the room sensor or the microswitch (if present).

- Reassemble the air filter.

DANGER: never switch the device on without first reassembling the fan coil housing.

The UVC radiation emitted by the internal lamps is dangerous and may cause conjunctivitis, burns and erythema.

The final touches to all procedures are, however, left to the experience of the installation engineer in accordance with the specific requirements.

The fan coil must be installed in such a position that the air can be distributed throughout the room and so that there are no obstacles (curtains or objects) to the passage of the air from the suction

louvers.

The fan coil should be installed in such a way as to facilitate the replacement of the germicidal lamp, routine maintenance (filter cleaning) and non-routine maintenance procedures, as well as providing access to the drain valve on the side of the unit frame (connector side).

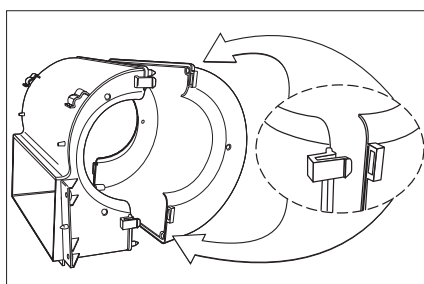
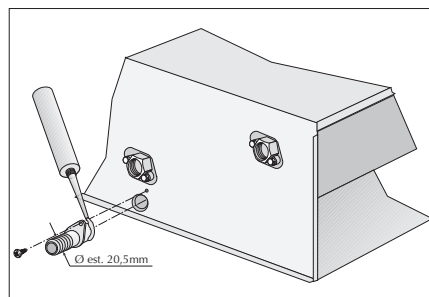
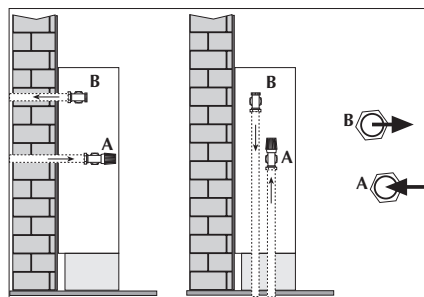
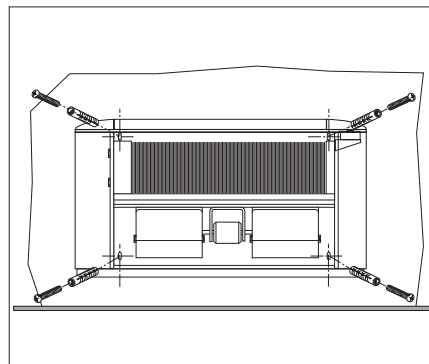
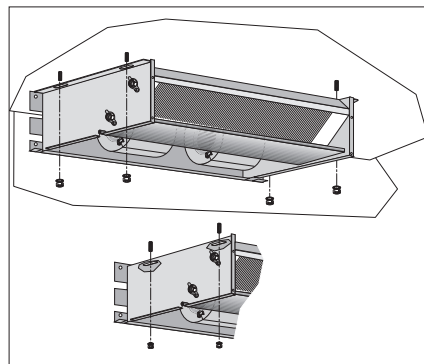
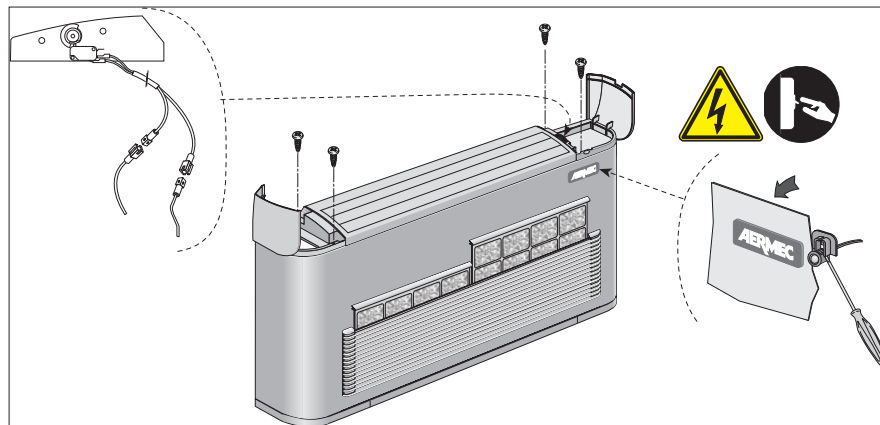

AERMEC	
INSTALLATION DATE	EMITTER CODE
CHANGE DATE	

FHX_UV / UVP / UVPO	EMITTER CODE
FHX 22 / 24	9114584
FHX 32 / 34	9114585
FHX 42 / 44	
FHX 50 / 54	
FHX 62 / 64	9114586
FHX 82 / 84	

ELECTRICAL WIRINGS

To protect the unit against short circuits, fit an omnipolar thermomagnetic breaker 2A 250V (IG) to the power line with a minimum contact opening distance of 3 mm.

Connection wire characteristics:

Use H05V-K or N07V-K type cables with 300/500 V with insulation, piped or ducted.

All the cables must be piped or ducted until they are inside the fan coil.

The cables coming out of the pipe or duct must not be subject to stretching or twisting. They must be protected from external agents.

Stranded wires can only be used with terminating sleeves. Make sure that the strands of the wires are inserted properly.

Wiring diagrams are constantly updated. It is therefore compulsory to refer to the ones supplied with the unit.

Each control panel can control a single fan coil.

The control panel may not be fitted on a metal wall unless this is permanently connected to an earthed outlet.

The control panels consist simply of elec-

tric circuits connected at the mains voltage of 230 V; all the inputs for the sensors and controls must therefore be correspondingly insulated for this voltage.

The PXAI control panel is fitted with a room temperature sensor and a water temperature sensor.

The PXAE control panel is fitted with a room temperature sensor; the water temperature sensor is available as a SW3 accessory.

The minimum water temperature sensor makes it possible to stop ventilation automatically if the temperature of the input water to the coil falls below 39°C. In installations with a three-way valve, the minimum water temperature sensor must be relocated from its standard mounting in the coil assembly to the delivery hose upstream of the valve. When relocating the water temperature sensor in the PXAI control panels, the standard sensor must be replaced with a SW3 sensor accessory, fitted with a cable of suitable length.

WARNING: the sensor is fitted with double insulation because it is subject to a voltage of 230 Vac.

When using control panels at a distance in conjunction with the fan coils, the corresponding electrical diagram must be observed.

For FHX-UV version fan coils (size between 22 and 50), connect the wires (already fitted inside the casing) for the MS microswitch controlling the opening of the air delivery louver to the MS terminals on the control panel.

The PXAI and PXAE multifunctional electronic thermostats must be made suitable for the specific requirements of the system using the internal Dip-Switches. **For FHX fan coils with germicidal lamp, the following parameters must be set: SW2, Dip1 and Dip2 in the ON position.**

In the wall/ceiling-mounted versions with boosted motor (PO), you can activate operation at the three speeds that can be selected from the seven available by choosing the relevant connections on the control board fitted to the motor.

WARNING: check whether the installation has been carried out correctly. Follow the checking procedures indicated in the control panel manuals.

REPLACING THE LAMPS

Germicidal lamps are available as a spare part from Aermec Technical Service Centres.

Make sure that the lamp is the same model as the one you are replacing; it is strictly prohibited to use lamps of different sizes.

DANGER! Before performing any maintenance procedures requiring access to the internal parts of the fan coil, cut off the power supply in order to avoid being exposed to the light emitted by the lamp. Never let yourself come into direct contact with the light produced by the lamp, as the UVC radiation may cause serious eye and skin irritation.

WARNING! Before starting to replace the lamp, cut off the power supply to the unit. Restore the power supply only once the lamp replacement procedure is complete. Non-observance of this regulation may cause the device to malfunction. If, after the lamp has been replaced, the germicidal lamp does not switch on because the correct procedure was not observed, cut off the power supply for at least 10 minutes and disconnect/reconnect the germicidal lamp to restore normal operation.

The lamp must be replaced every year so as to ensure the germicidal action remains constant.

ADVICE!

- Use suitable personal protective equipment.
- Handle the germicidal lamp with extreme caution, as it is fragile and contains mercury vapours.
- Observe current disposal legislation.
- Do not touch the glass surface of the germicidal lamp with your bare hands; if this should happen, use a clean cloth and isopropyl alcohol to remove the dirt accidentally deposited on the glass.

To replace the lamp, proceed as follows:

- Disconnect the unit from the power supply.
- Remove the lamp holder by turning it in an anticlockwise direction, then remove it from its slot.
- Slide the lamp out of the fan coil until the power supply cable of the lamp may be disconnected.
- Remove the lamp from the fan coil completely.
- Replace the lamp, taking care not to break it; the lamp should be disposed of in accordance with local legislation.

- Fit the new lamp (the same model), taking care not to touch the glass part with your fingers.
- Replace the lamp holder.
- Connect the power cable of the lamp.
- Make a note of the germicidal lamp replacement date on the data plate of the unit.
- Finish refitting the fan coil.
- Restore the power supply to the unit.

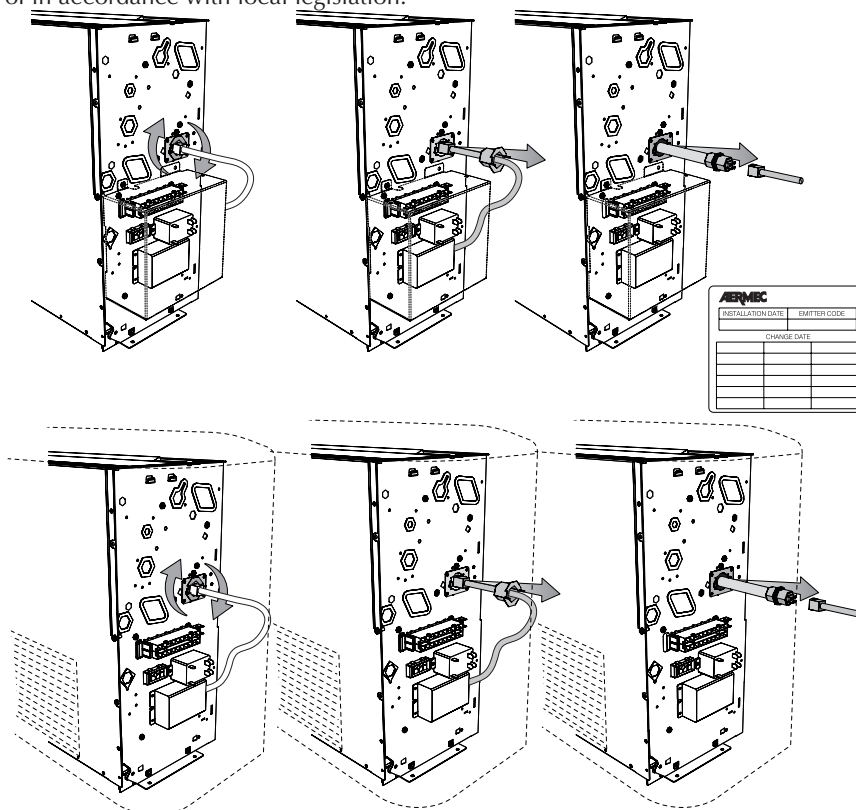

DIP-SWITCH CONFIGURATION

SETTINGS

To be carried out in the installation phase, only by suitably trained and qualified personnel.

Some functions are not compatible with each other and, for this reason, limits to Dip-Switch configurations have been set. By turning the Dip Switches inside the thermostat on or off, you can obtain the following functions:

Sw1 Dip 1 (Default OFF)

Water valve fitted:

- Present, set (ON).
- Not fitted, set (OFF).

Sw1 Dip 2 (Default OFF)

Position of the water temperature sensor:

- Water temperature sensor positioned upstream from the valve, set (ON).
- Water temperature sensor positioned downstream from the valve, set (OFF).

Sw1 ** Dip 3 (Default OFF)

Ventilation management:

- Continuous, set (ON), when the set-point is reached, the thermostat continues ventilating at the set ventilation.
- Thermostat-controlled, set (OFF), ON-OFF cycles are carried out at the selected speed.

Sw1 Dip 4 (Default OFF)

Sensor adjustment:

- Fixed adjustment, set (ON).
- Dynamic correction, set (OFF), calculated on the basis of the water temperature.

Sw1 Dip 5 (Default OFF)

Heating mode enabling temperature:

- Reduced, set (ON).
Minimum water temperature 35 °C.
- Normal, set (OFF).
Minimum water temperature 39 °C.

Sw1 Dip 6 (Default OFF)

Cooling mode enabling temperature:

- Reduced, set (ON).
Maximum water temperature 22°C
- Normal, set (OFF).
Maximum water temperature 17°C.

Sw2 * Dip 1 (Default OFF)

Selecting the fan coil type:

- Fan coil **with germicidal lamp, select (ON).**
- Fan coil without germicidal lamp, select (OFF).

Sw2 * Dip 2 (Default OFF)

Germicidal lamp detection:

- **Present, select (ON).**
- Not fitted, set (OFF).

Sw2 *** Dip 3 (Default ON)

Air temperature sensor enabling:

- Internal control panel sensor, select (ON).
- Sensor in fan coil, select (OFF).

Sw2 Dip 4 (Default OFF)

Option not available

NOTES:

* = Fan coils with germicidal lamp, mandatory settings: SW2 Dip1 and Dip2 in the ON position.

** = Continuous ventilation is only enabled in systems with valve (Sw1 Dip1 ON).

*** = For the proper functioning of the SA room sensor (INT), make sure that the Sw2Dip3 is in the ON position and the jumper set to the INT position.

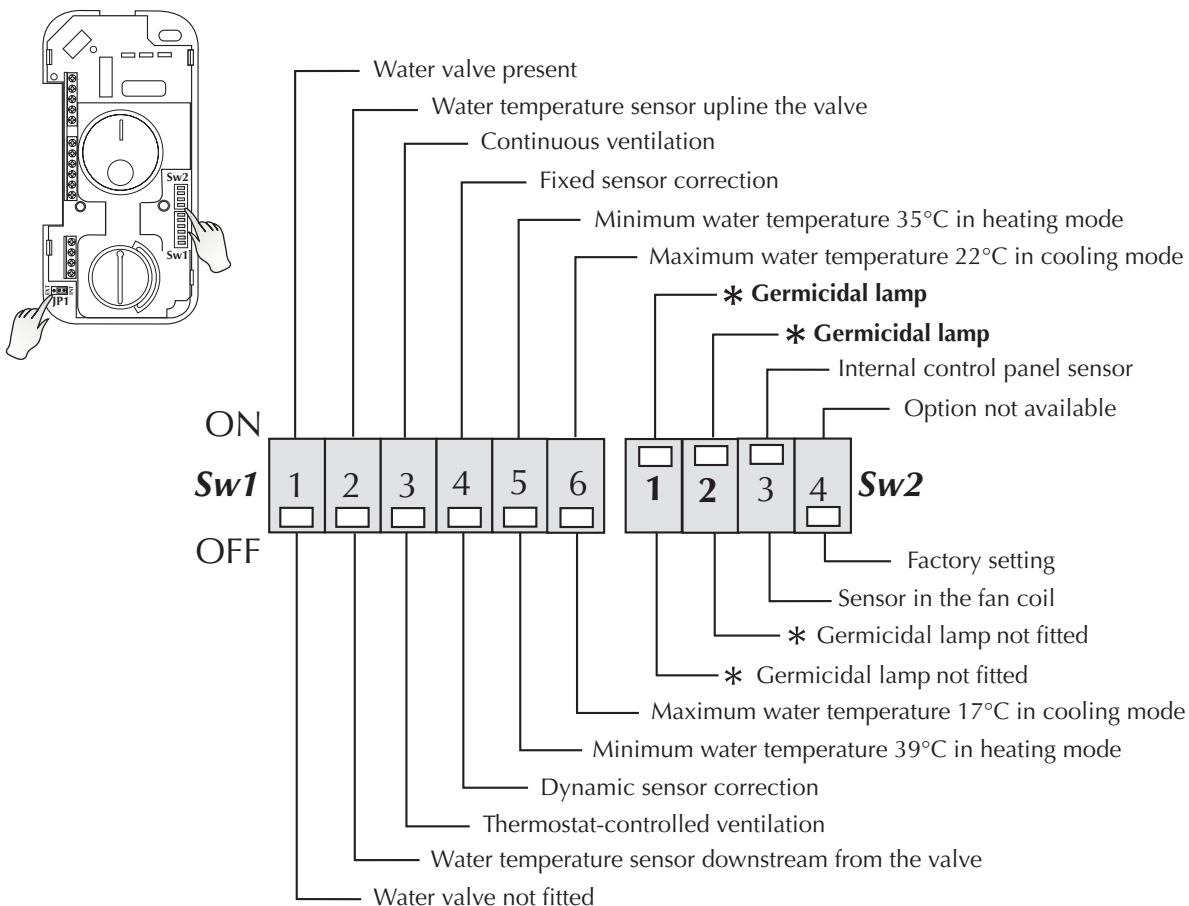

ROTATING THE COIL

WARNING! in the technical areas, make sure there is a suitable amount of space on the left-hand side of the unit for the lamp replacement procedure.

If plumbing connections require the rotation of the coil, remove the cover or the front closing panel (1) and proceed as follows:

- remove the condensate drip tray (3);
- remove the screws and remove the coil case (4);
- remove the screws securing the coil (5), then remove the coil;
- remove the push-outs (6) on the right side;

- remove the plate (12) from the left side (3 screws); the hole will be used when inserting the germicidal lamp (14);
- remove the lamp holder flange (13) from the right side and refit it to the left side;
- rotate the coil (5) and secure it using the screws removed previously;
- refit the cover (4), securing it with the screws and fit the plastic plugs (7) supplied into the holes left open by the plumbing connections; all the trays can be used for drainage on both sides. In case of vertical installation, for condensate drainage on the right side, position the drain connection to the right (8).

- slide out the electrical wirings from the right side, remove the push-out and move the cable guide (9) from the right to the left side;
- transfer the electrical wirings to the left side through the cable guide (9);
- move the control board (10), the ground jumper connection (11) and the electrical devices on the left side (15);

WARNING! close off the hole on the right side using the plate (12) previously removed from the left side.

English

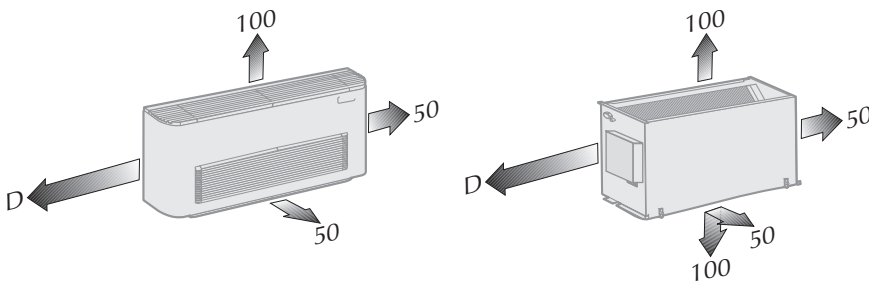
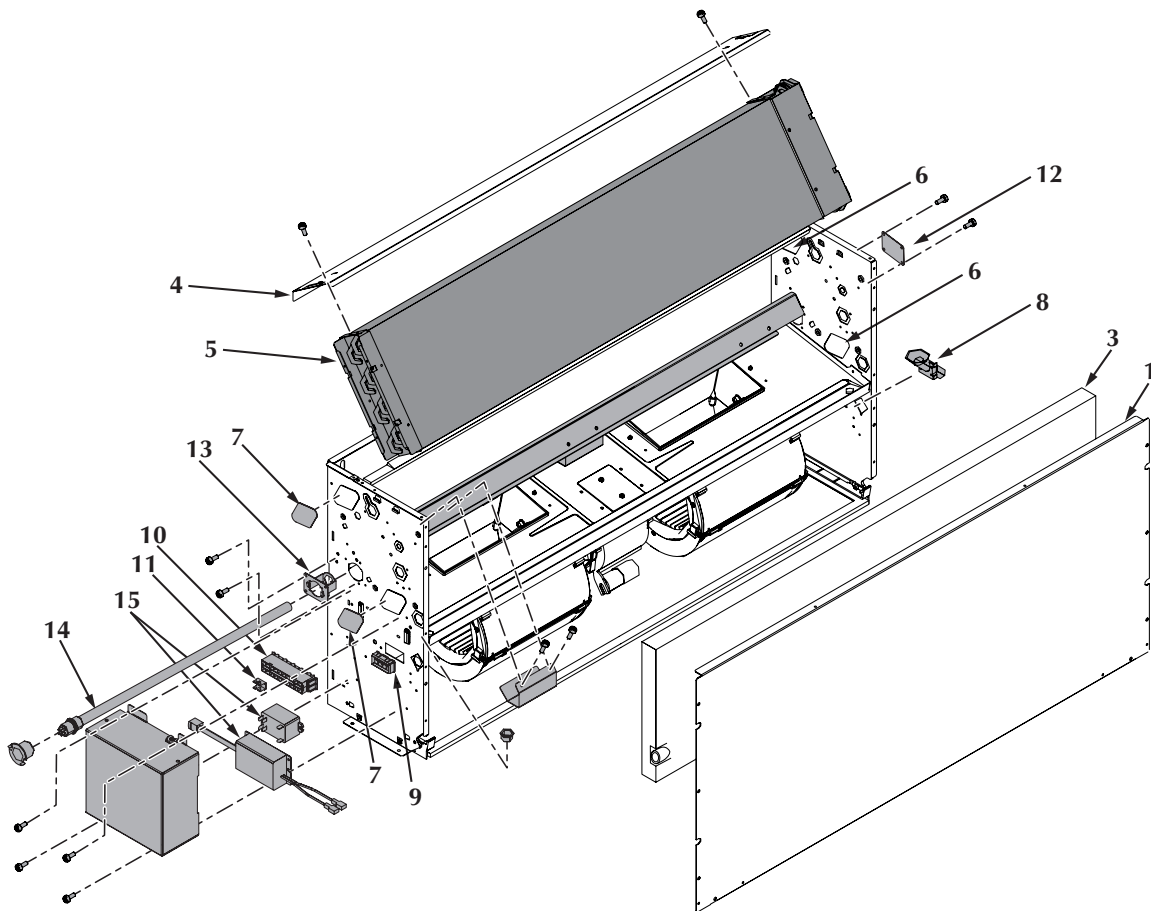

Models	FHX 22	FHX 32	FHX 42	FHX 50	FHX 62	FHX 82
D	415	620	620	620	925	925

TECHNICAL AREAS [mm]

Mod.	FHX 22	FHX 32	FHX 42	FHX 50	FHX 62	FHX 82
	FHX 24	FHX 34	FHX 44	FHX 54	FHX 64	FHX 84
D	415	620	620	620	925	925

FHX in standard factory-set default configurations (coil with connectors on the left)

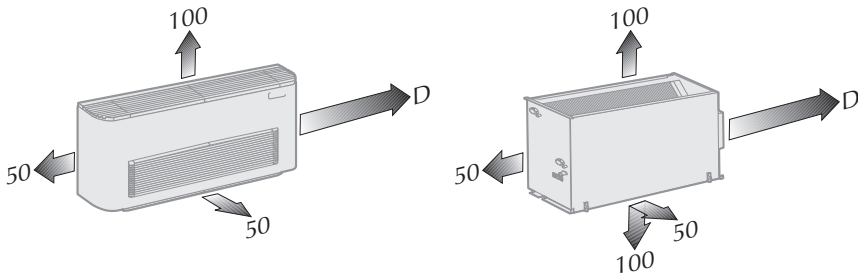

FHX with rotated coil (coil with connectors on the right)

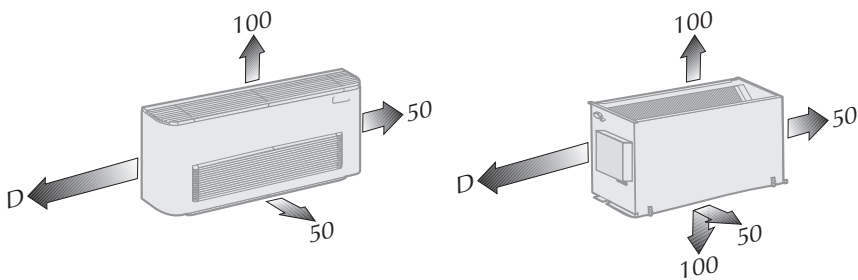

English

DATI DIMENSIONALI • DIMENSIONS • DIMENSIONS • ABMESSUNGEN • DIMENSIONES [mm]

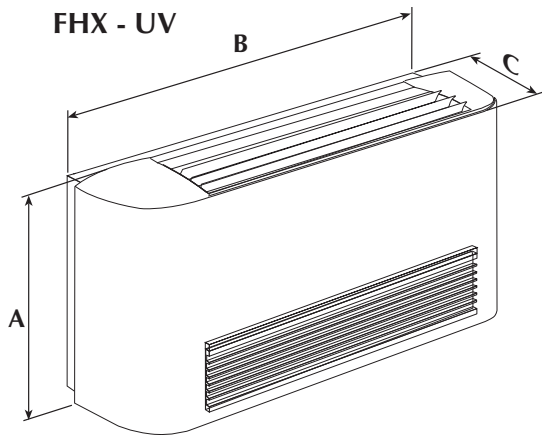

Mod. 22 - 32 - 42 - 50

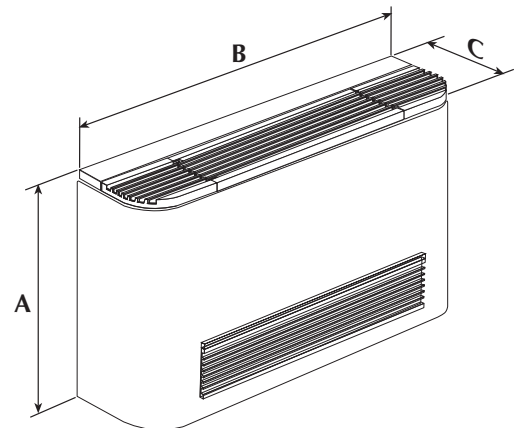

Mod. 62 - 82

Mod.	FHX 22	FHX 32	FHX 42	FHX 50	FHX 62	FHX 82	
	FHX 24	FHX 34	FHX 44	FHX 54	FHX 64	FHX 84	
A	520	520	520	520	590	590	
B	750	980	1200	1200	1320	1320	
C	220	220	220	220	220	220	
Peso Weight Poids Gewicht Peso	kg	16	26	25	25	35	35

English

FHX 22 - 32 - 42 - 50 UVP
 FHX 22 - 32 - 42 - 50 UVPO

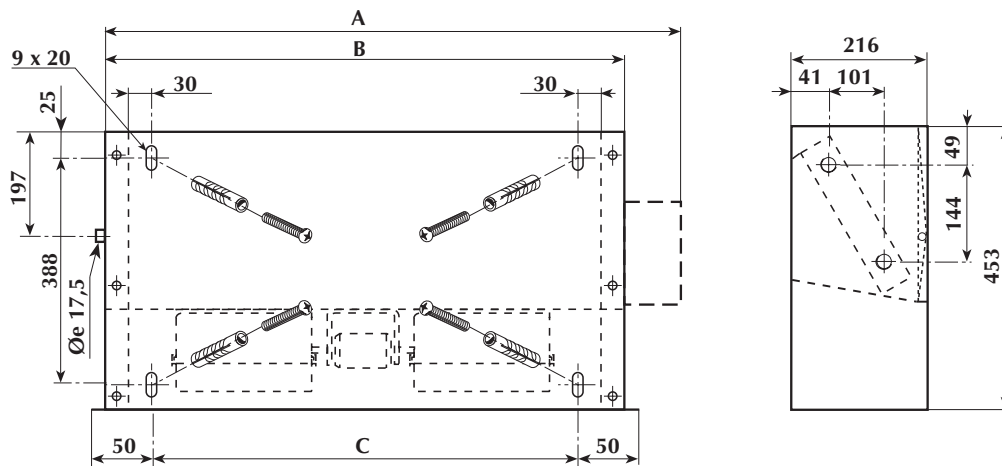

FHX 62 - 82 UVP
 FHX 62 - 82 UVPO

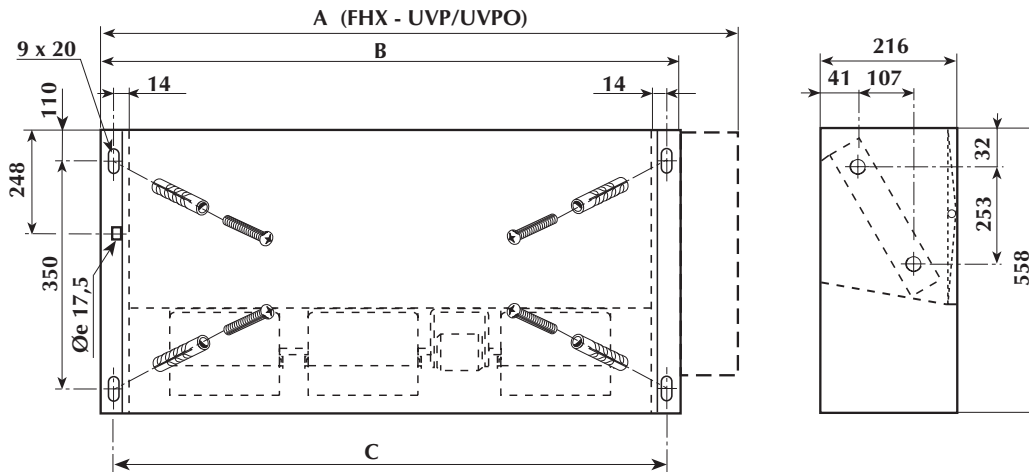

Mod.	FHX 22	FHX 32	FHX 42	FHX 50	FHX 62	FHX 82	
	FHX 24	FHX 34	FHX 44	FHX 54	FHX 64	FHX 84	
A	572	823	1043	1043	1205	1205	
B	522	753	973	973	1122	1122	
C	440	671	891	891	1102	1102	
Peso Weight Poids Gewicht Peso	kg	14	19	23	23	33	33

Attacchi batteria (femmina) • Coil connection (female)
 Raccords batterie (femelle) • Anschlüsse des Wärmetauschers (Innengewinde)
 Conexiones de la batería (hembra)

Mod.	FHX 22	FHX 32	FHX 42	FHX 50	FHX 62	FHX 82
3 R	1/2"	1/2"	3/4"	3/4"	3/4"	3/4"
Mod.	FHX 24	FHX 34	FHX 44	FHX 54	FHX 64	FHX 84
4 R	3/4"	3/4"	3/4"	3/4"	3/4"	3/4"

LEGENDA • READING KEY • LEGENDE • LEGENDE • LEYENDA

AL = Alimentatore 12V
Power supply 12V
Alimentation électrique 12V
Spannung 12V
Alimentador

CE = Contatto esterno
EX External contact
Contact extérieur
Externer Kontakt
Contacto externo

CN = Connettore
Connector
Connecteur
Schütz
Conector

CRE = Contattore resistenza elettrica
Electric heater contactor
Contacteur résistance électrique
El. Heizregister-Schutz
Contactor de la resistencia eléctrica

F = Fusibile • Fuse • Fusible
Sicherung • Fusible

IG = Interruttore generale • Main switch
Interupteur général • Hauptschalter
Interruptor general

M = Morsettiera • Terminal board
Boitier • Klemmleiste
Placa de bornes

ML = Motore aletta
Louvre motor
Moteur deflecteur
Motor- Umlenkklappe
Lamas motorizadas

MS = Microinterruttore griglia
(Solo per i modelli che ne sono provvisti)
Louvre microswitch
(Only for the appropriate models)
Micro-interrupteur grille
(Uniquement pour les modèles qui en sont fournis)
Mikroschalter Gitter
(Nur bei Modellen, die damit ausgestattet sind)
Microinterruptor de la rejilla de impulsión
(Sólo para los modelos que lo incluyen)

MV = Motore ventilatore • Fan motor
Moteur ventilateur • Ventilatormotor
Motor del ventilador

PE = Collegamento a terra
GND Earth connection
Mise à terre
Erdanschluss
Toma de tierra

RE = Resistenza elettrica • Electric heater
RX = Résistance électrique • El. Heizregister
Resistencia eléctrica

SA = Sonda ambiente • Room sensor
Sonde ambiente • Raumtemperaturfühler
Sonda ambiente

SC = Scheda di controllo
Electronic control board
Platine de contrôle • Steuerschaltkreis
Tarjeta electrónica de control

SW = Sonda minima temperatura acqua
Water low temperature sensor
Sonde minimum temp. eau
Wasserfühler
Sonda temperatura mínima del agua

TR = Trasformatore • Transformer
Transformateur
Transformator • Transformador

TSR = Termostato a riarmo automatico
Automatic resetting thermostat
Thermostat à réarmement automatique
Thermostat automatischer Entriegelung
Termostato de rearme automático

TSRM = Termostato a riarmo manuale
Manual resetting thermostat
Thermostat à réarmement manuel
Thermostat manuelle Entriegelung
Termostato de rearme manual

VCF = Valvola solenoide • Solenoid valve
Vanne solenoide • Magnetventil
Válvula solenoide

VC = Valvola solenoide caldo
Solenoid valve hot
Vanne magnétique chaud
Magnetventil Heizbetrieb
Válvula solenoide para calor

VF = Valvola solenoide freddo
Solenoid valve cold
Vanne magnétique froid
Magnetventil Kühlbetrieb
Válvula solenoide para frío

= Componenti non forniti
Components not supplied
Composants non fournis
Nicht lieferbare Teile
Componentes no suministrados

 = Componenti forniti optional
Optional components
Composants en option
Optionsteile
Componentes opcionales

 = Collegamenti da eseguire in loco
On-site wiring
Raccordements à effectuer in situ
Vor Ort auszuführende Anschlüsse
Cableado in situ

AR = Arancio • Orange • Orange • Orange • Naranja
BI = Bianco • White • Blanc • Weiss • Blanco
BL = Blu • Blue • Bleu • Blau • Azul
GR = Grigio • Grey • Gris • Gray • Gris
MA = Marrone • Brown • Marron • Braun • Marrón
NE = Nero • Black • Noir • Schwarz • Negro
RO = Rosso • Red • Rouge • Rot • Rojo
VE = Verde • Green • Vert • Grün • Verde
VI = Viola • Violet • Violet • Violet • Violeta

English

SCHEMA DI COLLEGAMENTO MOTORE FHX - PO • FHX - PO MOTOR CONNECTION DIAGRAM
SCHEMA DE RACCORDEMENT MOTEUR FHX - PO • ANSCHLUSSPLAN MOTOR FHX - PO
ESQUEMA DE CONEXIONADO ELÉCTRICO DEL MOTOR FHX - PO

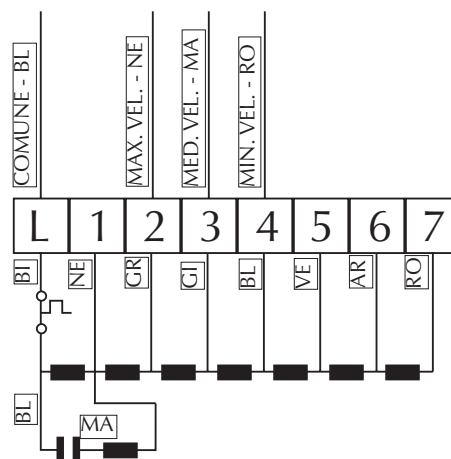

Le velocità disponibili sono numerate da 1 a 7 in ordine decrescente di velocità
Available speeds are numbered from 1 to 7 following a speed decreasing order
Les vitesses disponibles sont numérotées de 1 à 7 en ordre de vitesse décroissante
Die verfügbaren Drehzahlen sind von 1 zu 7 mit abnehmender Drehzahlstufe nummeriert
Las velocidades disponibles se numeran, en orden decreciente, de 1 a 7.

Gli schemi elettrici sono soggetti ad un continuo aggiornamento, è obbligatorio quindi fare riferimento a quelli a bordo macchina. All wiring diagrams are constantly updated. Please refer to the ones supplied with the unit. Nos schémas électriques étant constamment mis à jour, il faut absolument se référer à ceux fournis à bord de nos appareils. Die Schaltpläne werden ständig aktualisiert, deswegen muss man sich stets auf das mit dem Gerät gelieferte Schaltschema beziehen. El cableado de las máquinas es sometido a actualizaciones constantes. Por favor, para cada unidad hagan referencia a los esquemas suministrados con la misma.

English

Dis. 5578450_00

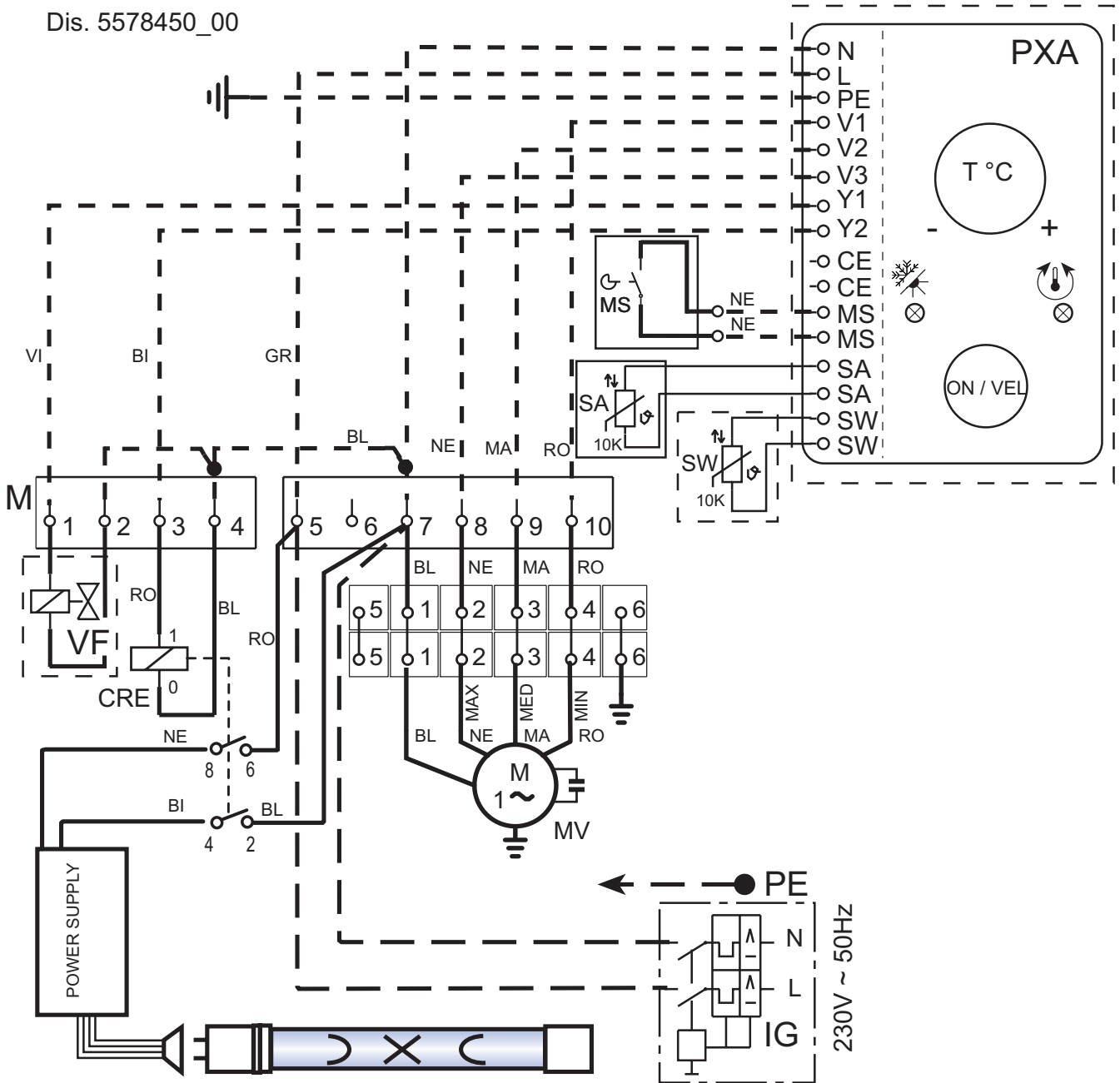

Gli schemi elettrici sono soggetti ad un continuo aggiornamento, è obbligatorio quindi fare riferimento a quelli a bordo macchina. All wiring diagrams are constantly updated. Please refer to the ones supplied with the unit. Nos schémas électriques étant constamment mis à jour, il faut absolument se référer à ceux fournis à bord de nos appareils. Die Schaltpläne werden ständig aktualisiert, deswegen muss man sich stets auf das mit dem Gerät gelieferte Schaltschema beziehen. El cableado de las máquinas es sometido a actualizaciones constantes. Por favor, para cada unidad hagan referencia a los esquemas suministrados con la misma.

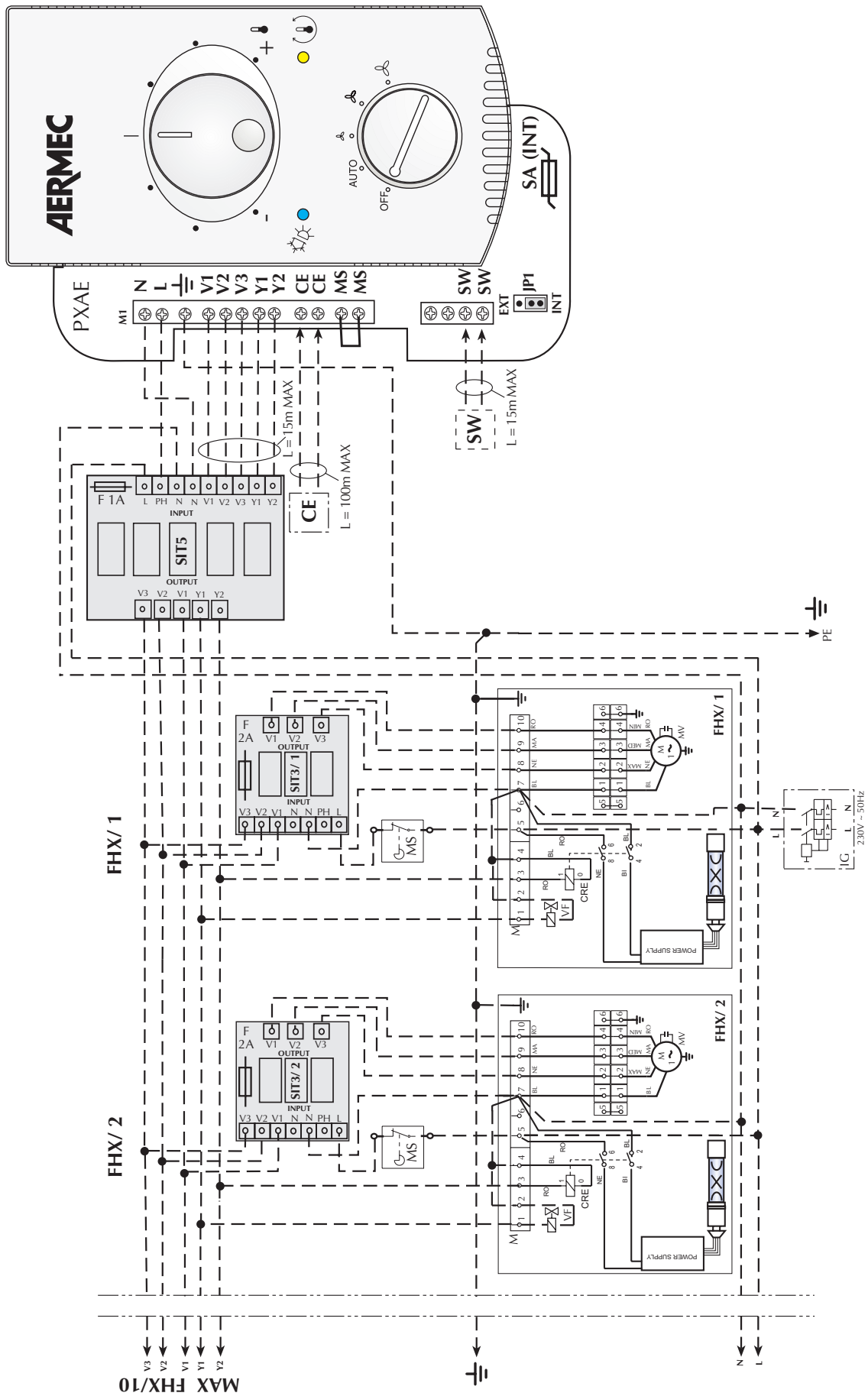

English

Gli schemi elettrici sono soggetti ad un continuo aggiornamento, è obbligatorio quindi fare riferimento a quelli a bordo macchina. All wiring diagrams are constantly updated. Please refer to the ones supplied with the unit. Nos schémas électriques étant constamment mis à jour, il faut absolument se référer à ceux fournis à bord de nos appareils. Die Schaltpläne werden ständig aktualisiert, deswegen muss man sich stets auf das mit dem Gerät gelieferte Schaltschema beziehen. El cableado de las máquinas es sometido a actualizaciones constantes. Por favor, para cada unidad hagan referencia a los esquemas suministrados con la misma.



Aermec partecipa al Programma di Certificazione EUROVENT. I prodotti interessati figurano nella Guida EUROVENT dei Prodotti Certificati.

Aermec adheres to the EUROVENT Certification Programme. These products are listed in the EUROVENT Directory of Certified Products.

Aermec partecipe au Programme de Certification EUROVENT. Les produits figurent dans l'Annuaire EUROVENT des Produits Certifiés.

Aermec ist am Zertifikations - Programm EUROVENT beteiligt. Die entsprechend gekennzeichneten Produkte sind im EUROVENT - Jahrbuch aufgeführt.

AERMEC S.p.A. participa en el programa de certificación EUROVENT. Sus equipos aparecen en el directorio de productos certificados EUROVENT.

I dati tecnici riportati nella presente documentazione non sono impegnativi.

AERMEC S.p.A. si riserva la facoltà di apportare in qualsiasi momento tutte le modifiche ritenute necessarie per il miglioramento del prodotto.

Les données mentionnées dans ce manuel ne constituent aucun engagement de notre part. Aermec S.p.A. se réserve le droit de modifier à tous moments les données considérées nécessaires à l'amélioration du produit.

The technical data in this documentation are not binding.

Aermec S.p.A. reserves the right to make whatever modifications it deems necessary to improve the product at any time.

Im Sinne des technischen Fortschrittes behält sich Aermec S.p.A. vor, in der Produktion Änderungen und Verbesserungen ohne Ankündigung durchzuführen.

Los datos técnicos indicados en la presente documentación no son vinculantes.

Aermec S.p.A. se reserva el derecho de realizar en cualquier momento las modificaciones que estime necesarias para mejorar el producto.

AERMEC S.p.A.

I-37040 Bevilacqua (VR) - Italy

Via Roma, 44 - Tel. (+39) 0442 633111

Telefax (+39) 0442 93730 - (+39) 0442 93566

www . aermec . com